



Agriculture
Canada

Publication 1848/E



Wire fences for livestock management

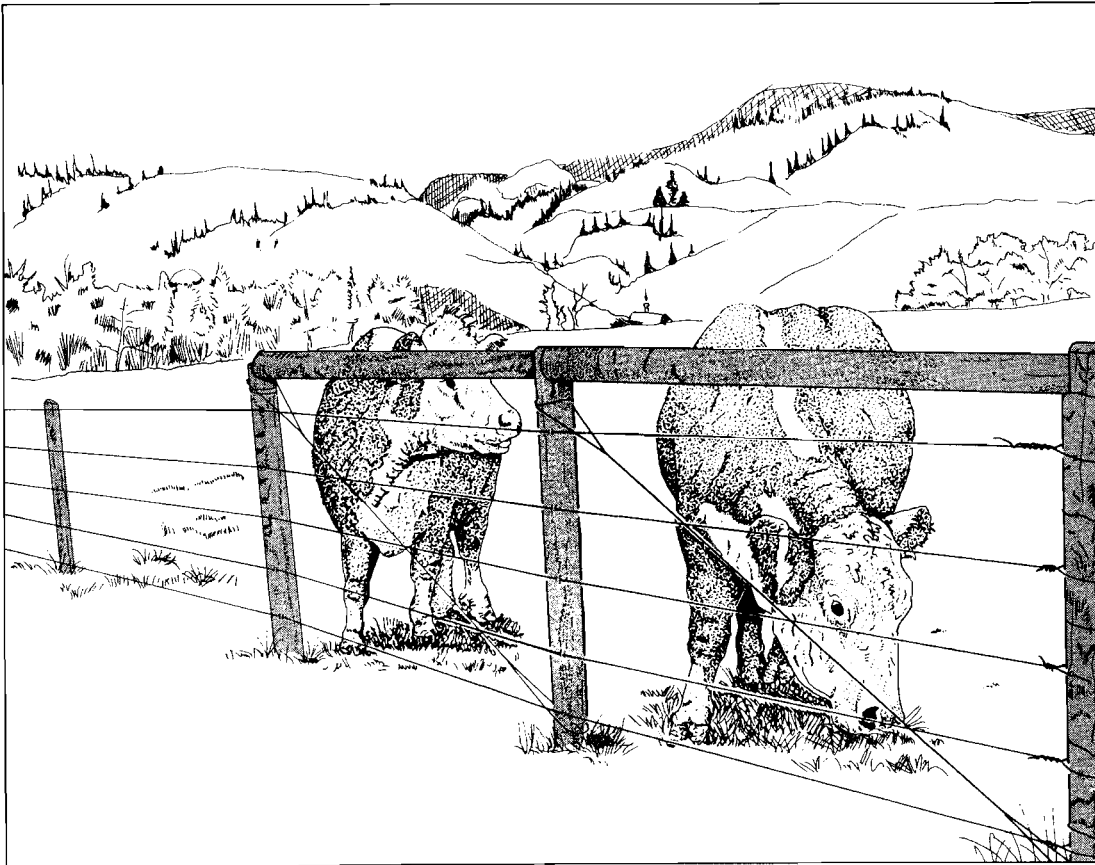

Canada

Wire fences for livestock management

D.A. Quinton
Research Station
Kamloops, B.C.

Cover illustration
Five-wire range fence

Agriculture Canada Publication 1848/E
available from
Communications Branch, Agriculture Canada
Ottawa K1A 0C7

©Minister of Supply and Services Canada 1990
Cat. No. A53-1848/1990E ISBN 0-662-17718-5
Printed 1990 3.5-09:90

Également disponible en français sous le titre
Clôtures de fils pour la conduite du bétail

CONTENTS

Introduction 6

Fence components 6

Braces 7

Posts 7

Wire 8

Fasteners 8

Droppers 8

Basic principles 8

Post spacing 8

Wire properties 9

Elasticity 9

Stapling 9

Temperature 10

Brace assemblies 11

Fence materials 12

Wooden posts 12

Types of droppers 15

Types of wire 16

Types of fasteners 17

Staples 17

Dowel pins and spikes 17

End-post fasteners 17

Wire splicers 19

In-line strainers and tension springs 20

Tools 21

Special tools 21

Common tools 23

Planning the fence 23

Boundaries 23

Laws 25

Hazards 25

Terrain 25

Soils 25

Performance 25

Location 25

Preplan 26

Specifications 26

Four-wire barbed-wire range fence 26

Five-wire range fence 27

Six-wire high-tensile livestock fence 28
Eight-wire high-tensile livestock fence 28
Ten-wire high-tensile livestock fence 29
Ten-wire high-tensile cattle feedlot fence 29
Twelve-wire high-tensile horse fence 30

Laying out 31

Across level terrain 31
Over uneven terrain 31
Around curves 31

Construction 33

Clearing the line 33
Placing end, corner, and gate posts 33
Stringing the guide wire 34
Constructing brace assemblies 37
Driving line posts 42
Stringing line wires 43
Tensioning line wires 45
Stapling 45
Installing droppers 48

Gates 49

Safety 50

Acknowledgments 52

INTRODUCTION

Fences are a vital part of livestock and forage management systems. Although they are mainly used to confine or exclude various kinds and sizes of livestock, fences also influence animal movements and behavior. Without good fences there would be no protection for crops, no control over breeding, feeding, or safety of livestock, and no established boundaries for rangeland.

Originally, fences consisted of stone walls or barriers of logs or stumps placed around highly productive fields and buildings for protection. Fencing then evolved into a management tool used to obtain more benefit from less-productive lands. Its first practical use on an extensive scale came with the introduction of barbed wire in the late 19th century and the introduction of woven wire a few years later. After the introduction of cheap wire, there was minimal development in fencing technology or in understanding of the role of fence components. Posts were spaced one log apart and wires were tightly attached to them to simulate the rigidity of logs. Posts were eventually treated to curtail rot and were sharpened and set by pounding rather than by backfilling and tamping, but little else changed until recent years.

Today's high costs for land, machinery, fertilizer, fuel, feed and farm materials, and labor have dictated more-efficient use of land. These economic conditions, plus the need to replace many fences erected with inexpensive labor and materials in the 1940s, have intensified the need for good, low-cost fences. This need has, in turn, led to research to identify what constitutes good fences and fencing methods. This research has led to the use of high-tension (136-kg stress) fences constructed of either barbed wire or smooth, high-tensile wire and to electrification of the latter. The best fence is the lowest-cost fence that will do the required job over the longest time.

FENCE COMPONENTS

The basis of a modern fence is a pair of anchors termed brace assemblies, between which wires are strung. Posts are set in line between the brace assemblies to maintain wire spacing and to support the wires. The wires are loosely attached to the posts with staples. Wire spacing is further stabilized by the attachment of droppers or stays. All these components act together as a unit in which resilient materials, correct anchoring, and a good right-of-way are exploited to produce an economical and effective fence.

BRACES

To understand fence function and performance, it is necessary to know the forces placed on a fence. Most 12-1/2 gage wire used today has a breaking strength of 450 kg for barbed wire and 590 kg for smooth (high-tensile) wire. A brace assembly with five wires attached, each tightened to 136 kg tension will thus have to hold a sustained force load of 680 kg. As the anchors for the fence and the component giving it strength, the brace assemblies must withstand the tensioned force of the wires plus any additional forces up to the point at which the wires break.

POSTS

Posts and their setting are the most expensive items in fence construction. Therefore, the fewer posts required, the less expensive a fence will be. The primary functions of line posts are to maintain proper wire spacing, to absorb some of the weight of the wire, to prevent overturning, and to add visibility to the fence; they are not required to add appreciable strength or rigidity to the fence. Thus line posts can be spaced at intervals from 10 to 30 m apart. The actual post spacing is dependent upon the terrain and the purpose of the fence. Research has shown that fencing costs are not appreciably reduced with post spacings greater than 18 m (Fig. 1).

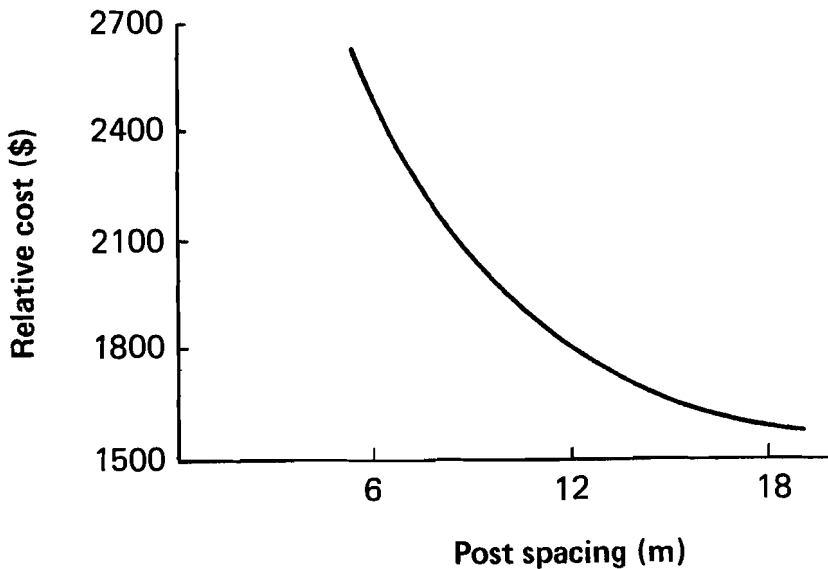

Fig. 1 Post spacing versus fence costs.

WIRE

Fence wire is a restraining tool that plugs the holes between posts and brace assemblies. High-tension wire should be sufficiently elastic to withstand applied stress forces and should be galvanized to retard rust. Barbed wire must be prestressed to 270 kg to straighten the twists before it will behave elastically to applied forces. High-tensile wire, being a single strand, does not need prestressing. Wire should be attached firmly to brace assemblies at a standard tension of 136 kg at 0°C or equivalent.

The barbs on wire are essentially a holdover from the days of low-tensile strength wire when it was believed that they were an important deterrent to animals. Research has shown that the elastic, unified performance of modern fence designs is a more effective deterrent. A panel of wire fence, cross braced with droppers, moves with the animal challenging it, yet does not allow the wires to be spread and the fence breached.

FASTENERS

Staples or fasteners are the means by which wire is attached to brace assemblies and the means by which wire spacing is maintained on line posts. A flat surface on either leg of the staple acts as a wedge and guides the path of each leg through the wood. Being spacing tools rather than attaching tools, staples should not be driven tightly against the wire on line posts. Leaving a space between the staple crown and the wire on line posts allows the wire to slide between the staple and the post. This allows for expression of elastic action of the wire and distributes stress loads over the entire length of the wire. Conversely, driving staples tightly against the wire on line posts results in short, independent, more rigid lengths of fence that will stretch or break under stress loads.

DROPPERS

Droppers, or stays, are used both to maintain wire spacing between posts and to give visibility to the fence. They also function in distributing stress forces over all the fence wires. Droppers should be inexpensive, easily attached, and strong enough to resist bending or breaking under stress loads.

BASIC PRINCIPLES

POST SPACING

Common practice and belief is that fence posts must be close together with wire tightly attached to them to make a strong fence.

However, with tensioned wire, the reverse is true. When an impact force is applied to a fence wire, the lateral forces acting on the posts lessen as distance between them increase (Fig. 2).

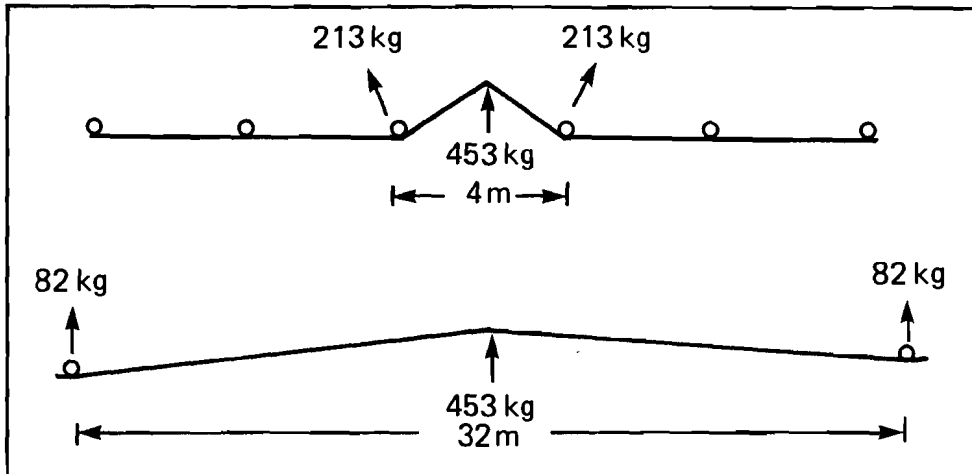

Fig. 2 Effect of post spacing on lateral loads applied to a fence.

Thus, closely spaced posts absorb more of the force of an impact on the wires and the chance of post failure, by breaking or overturning, increases. If the staples holding the wires have been driven tightly against the wire, the problem is compounded. These short spans behave as individual fences and are required to absorb the total stress load applied to them, greatly increasing the chance of failure of both posts and wires.

WIRE PROPERTIES

Elasticity

Pretensioned (straightened) barbed wire and high-tensile steel wire elongate at a rate proportional to an applied tension, up to the elastic limit or yield point of the wire. The stress-strain relationship is approximately linear to the yield point, which is about 80% of the breaking strength of the wire. A wire subjected to a tension less than the yield point will return to its original length when tension is removed. However, if the tension exceeds the yield point, the wire will stretch permanently.

Stapling

Driving staples tightly against the wire on line posts interferes with the wire's elasticity and reduces the wire's tolerance to impacts. Little force is required to deflect such rigid wires and even small forces result in the generation of large wire tensions in short spans of fence.

However, if the staples are not driven tightly against the wire the deflection caused by an impact is distributed over a greater length of wire and the elongation per metre of wire is tiny. As a result, a minimal increase in wire tension is generated. To illustrate this principle consider the following:

- post spacings of 6 m
- elongation rate per metre of wire of 0.93 mm/100 kg
- original wire tension of 136 kg
- brace assemblies (wire attached tightly) spaced 200 m apart.

Condition 1 Staples are driven to hold wire tightly to line posts and a force sufficient to deflect a wire 30 cm is applied.

Solving the triangle, the resultant elongation in the wire is then 30 mm over the 6-m wire or 5 mm per each metre of wire. Because wire elongates at 0.93 mm/m for each 100 kg applied, an elongation of 5 mm/m results in an increase in tension of about 538 kg. Because the wire was originally tightened to 136 kg tension, this increase would exceed the tensile strength of the wire. If the staples and posts hold, the wire would break. Otherwise, posts would pull loose, staples would pull out, and the wire would stretch permanently.

Condition 2 Staples are driven to allow wire movement between post and crown of staple and a force sufficient to deflect a wire 30 cm is applied.

Solving this triangle, the resultant elongation in the wire is then 30 mm spread over 200 m of wire or 0.15 mm per each metre of wire. Because wire elongates at 0.93 mm/m for each 100 kg of load applied, an elongation of 0.15 mm/m results in about a 16-kg increase in tension.

This increase, added to the original tension (136 kg + 16 kg), is well within the elastic limit of the wire. The wire would withhold the force (turn the animal) and return to its original length and tension when the force was removed. There would be no damage to the fence.

Remember—when the staples are driven to hold the wire tightly to line posts, relatively small deflections (small loads) result in relatively large wire tensions and the yield point of wire is more likely to be exceeded. The wire and fence are then more susceptible to permanent damage, sagging, and failure.

Temperature

Another factor to consider is expansion and contraction of wire with changing temperatures. A 5°C change in temperature results in a 5-kg change in wire tension, independent of length. Thus either make allowances for temperature when tightening fence wires, or incorporate in the fence a means by which wire tension can be readily changed. Recommended wire tension is 136 kg at 0°C, 126 kg at 10°C, 116 kg at 20°C, and so on.

BRACE ASSEMBLIES

Braces are the anchors for the fence wire so must be as square and as strong as possible. Place brace assemblies as far apart as the terrain will allow, up to a maximum separation of 400 m.

Brace posts generally rotate on their axis in shifting to equilibrium when tension is applied and brace components come under compression. Only 25 mm of such movement can reduce tension by half in a 100-m span. Thus a tension of 45 kg in a 100-m fence is reduced to 23 kg. However, the same movement (25 mm) in a 200-m fence only reduces the tension by one-quarter from 45 kg to 34 kg.

Test results of the force at failure of several types of brace assemblies (Fig. 3) are given in Table 1. Because all double brace assemblies tested were strong enough to withstand forces sufficient to break the fence wires, type 3 was selected as the standard for end and corner braces. This brace is easy to build, compensates for less-exacting workmanship, and is aesthetically pleasing. Where a single brace is desired, a type 4 brace would give sufficient strength but must be built to exacting specifications.

**Table 1 Strength of brace assemblies at failure using posts
215 cm × 127 mm driven 76 cm**

Brace type	Single braces		Double braces	
	Deflection at 680 kg (mm)	Load at failure (kg)	Deflection at 680 kg (mm)	Load at failure (kg)
1	15.2	1633	8.6	2721
2	19.6	1451	12.2	2520
3	29.0	1315	12.4	2520
4	3.3	2540	3.3	2721
5	8.4	1769	3.6	1860
6	4.3	1451	2.3	2721

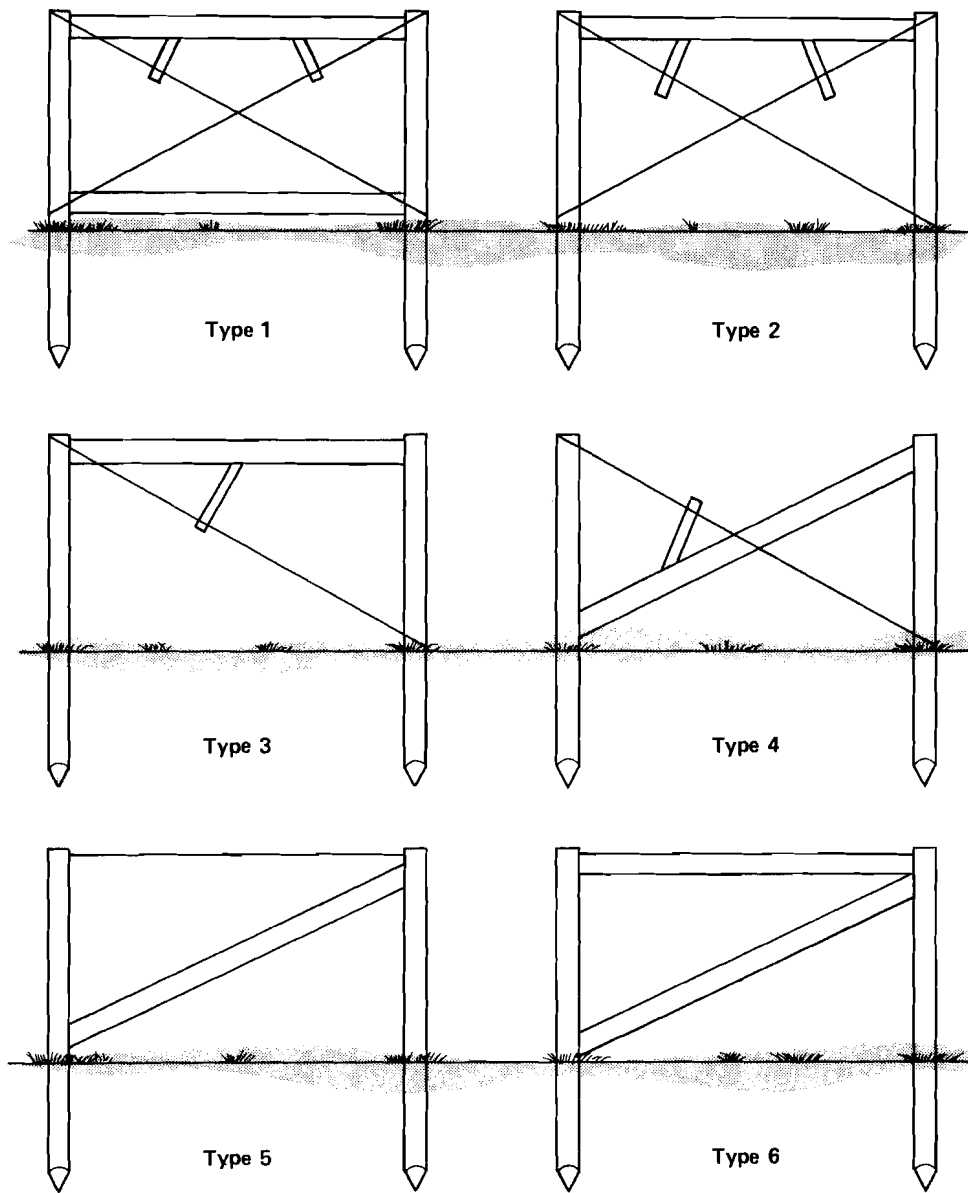

Fig. 3 Types of brace assemblies tested.

FENCE MATERIALS

WOODEN POSTS

The most suitable material for high-tension and high-tensile fence construction is wood—specifically, sharpened round wooden posts that can be driven into the ground and that have been chemically treated to resist rot. Softwood posts, such as pine, absorb chemicals well, are

light in weight, are fairly strong and inexpensive, and have a long life expectancy.

Pressure-treated posts are relatively straight and are sharpened to facilitate driving. Posts vary in diameter from end to end and from post to post. All diameters specified in this publication are minimum recommendations and refer to the smallest end of the post.

Posts, treated to resist weather, rot, fire, and termites, are available. Properly treated under pressure, they will last up to 40 years. Avoid posts that have been dipped, soaked, or had preservative brushed on them. Such posts may be inexpensive, but they are poor value. They will last only a relatively short time before they will need replacement. Posts used in brace assemblies must be strong enough to withstand the wire tension of the entire fence as well as to absorb impact stresses without failing. By themselves, wires can exert forces on end posts that exceed 1100 kg for a 10-wire fence. Line posts must carry part of the weight of the wire and must absorb part of any impact forces acting on the wire. Test results for pressure-treated pine posts are given in Fig. 4 and Table 2.

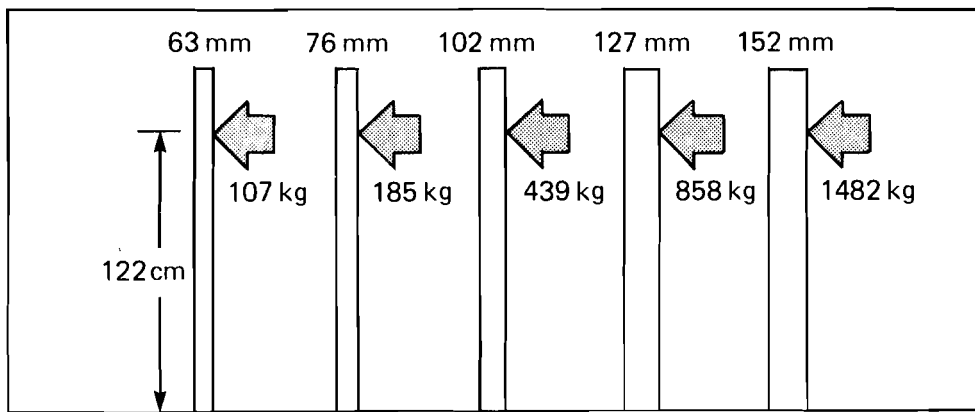

Fig. 4 Average breaking strengths for pressure-treated pine posts with loads steadily applied.

Several types of treated posts are available from reputable manufacturers. Before purchasing posts, buyers should satisfy themselves with the quality of preservative and methods of preserving used. It is too late to return an inferior product after it has been in the ground for 1 or 2 years.

Preserving chemicals can cause reactions in people susceptible to allergies. Use protective full-length clothing, gloves, and eye or face shields when working with chemically treated posts.

Table 2 Lateral load-bearing capacities of driven posts

Size (mm)	Soil	Depth driven (cm)	Force (kg)	Failure
102	Soft clay	76	45	overturn ¹
	Medium clay	76	408	overturn
	Stiff clay	76	635	lean
	Very stiff clay	76	680	lean
102	Soft clay	107	84	overturn
	Medium clay	107	590	overturn
	Stiff clay	107	748	lean
	Very stiff clay	107	771	lean
102	Soft clay	122	104	overturn
	Medium clay	122	601	overturn
	Stiff clay	122	771	lean
	Very stiff clay	122	794	lean
127	Soft clay	122	136	overturn
	Medium clay	122	998	overturn
	Stiff clay	122	1474	lean
	Very stiff clay	122	1520	lean
152	Soft clay	122	186	overturn
	Medium clay	122	1451	overturn
	Stiff clay	122	2449	overturn
	Very stiff clay	122	2540	lean

¹ Greater than 130-mm lean.

Recommendations

Penta-treated posts Pentachlorophenol is a wood preservative used to treat softwood posts. The dry chemical is mixed with oil and forced into the wood in a pressure chamber. Pentachlorophenol crystals remain in the wood when the pressure is removed. Penta-treated posts should either contain a minimum of 4.0 kg of pentachlorophenol per cubic metre of wood or meet CSA Standard 080.5.

CCA treated posts Chromated copper arsenate (CCA) dissolved in water is an excellent preservative for wood posts. After pressure treating, evaporation of the water leaves the salt, which is poisonous to decay fungi and insects, deposited in the wood. These posts are dry, do not have an oil residue, and can be painted. They are a light green color after treatment. CCA-treated posts should either contain a

minimum of 6.4 kg of chromated copper arsenate per cubic metre of wood or meet CSA Standard 080.5.

Pressure-creosoted posts Creosote is the oldest and most widely used wood preservative. Pressure-creosoted posts give excellent protection against moisture, insects, and decay, and are resistant to grounding if the fence is electrified. They can be expected to last an average of 35 years and up to 70 or more years under dry conditions. These posts are fire-retardant in that they surface char and then self-extinguish. Pressure-creosoted posts should either contain a minimum of 96.0 kg of creosote per cubic metre of wood or meet CSA Standard 080.5.

TYPES OF DROPPERS

On even-contoured terrain, the post spacing of range fences can be 18 m or greater if droppers are installed between the line posts. The number of droppers depends on the type of livestock and the intensity of pressure on the fence. Under range conditions with light-to-moderate livestock pressure on fences, one dropper every 6 m is adequate. One dropper every 3 m is recommended for moderate-to-heavy livestock pressure and one dropper is required every 1.5 m for heavy livestock pressure.

Droppers should not bend with normal impacts on fences. They should maintain wire spacings at all times and should have a life expectancy equal to that of the rest of the fence. Many types of droppers are available in Canada. For most conditions either wooden or sheet metal droppers are recommended (Fig. 5). Wooden droppers should be sufficiently rot-resistant to last as long as the fence. Wood droppers are often made from cut saplings in forested areas, from treated 25 × 100 mm lumber, or from 38 × 38 mm split cedar. Sheet metal droppers are made from 18-gage galvanized steel. Another popular dropper, which is inexpensive and easy to install, is made from twisted wire. However, these droppers bend permanently under very light loads or impacts. Because of this, use twisted wire droppers only on fences subjected to very light livestock pressure.

Because droppers are not driven into the ground, they must be firmly attached to the fence wires. Droppers may be smooth, notched, or grooved to accept fence wire and either snap-on or are wired or stapled onto the fence wires.

If slotted wood or sheet metal droppers that snap onto the wire are used, ensure that the droppers will not slide along the wire after installation (Fig. 5). Movement is best prevented by ensuring that the wire grooves are slightly offset during manufacture.

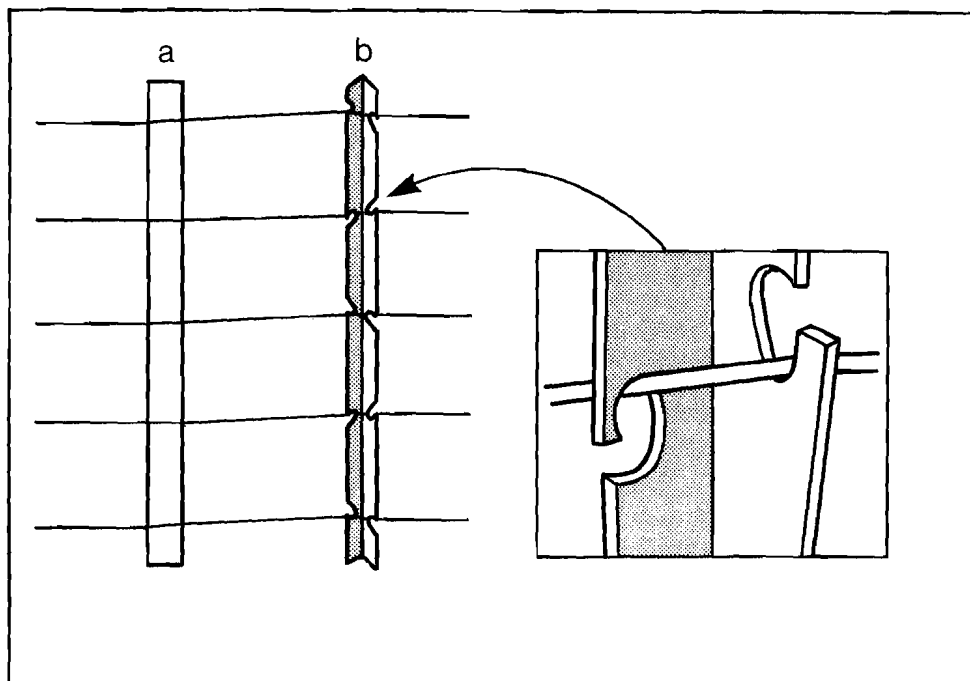

Fig. 5 (a) Angle-grooved wood and (b) snap-on metal droppers.

TYPES OF WIRE

All wire for high-tension and high-tensile fences should be 12-1/2 gage, triple-galvanized (Type III) steel wire. To be safe and function properly, barbed wire should have a tensile strength of at least 4900 kg/cm². High-tensile wire should have a tensile strength of at least 9800 kg/cm². Table 3 shows a comparison between characteristics of barbed and high-tensile wire.

Advantages of high-tensile over barbed wire

- It is cheaper than barbed wire (less than half price for equal length).
- It is easier to string out and handle. All the wires can be strung out and tightened in the same operation because there are no barbs to tangle with other wires or vegetation. This feature alone can save walking 9 km for each 1.6 km of five-wire fence constructed.
- It is safer for livestock and wildlife, no barbs to damage hide.
- It behaves elastically along the entire length of wire because there are no barbs to hang up on staples. Thus it tolerates greater shock loads.
- It requires no prestretching to obtain elastic properties.
- It has a greater tensile strength than barbed wire of the same gage.

Table 3 Wire specifications

Wire type	Gage	Dia- meter (mm)	Breaking strength		Elastic limit	
			(kg)	(kg/cm ²)	(kg)	(kg/cm ²)
Barbed	12-1/2	2.54	431	4 921	399	4 007
High-tensile tying	12	2.69	590	10 545	499	8 928
High-tensile fence	12-1/2	2.46	644	12 441	485	10 179
Max-ten 200™ fence	12-1/2	2.51	823	16 576	735	14 760

TYPES OF FASTENERS**Staples**

It is recommended that staples (Fig. 6) not be fully driven into line posts. Thus longer staples are needed. These should be 45 mm long, corrosion resistant with opposing slash cut points. Galvanized staples have a greater holding power than smooth staples. Staples should number about 60 per 450 g.

Dowel pins and spikes

Dowel pins of varying length or spikes, will be needed for constructing brace assemblies. Both should be corrosion resistant. Spiral spikes will hold better than smooth or coated spikes, but are difficult to remove.

End-post fasteners

Wire may be tied off at end, corner, and gate posts by using various knots. Tests have shown that these reduce wire strength by 40% and are the weakest part of the fence. They are presented here as an alternative to mechanical fasteners.

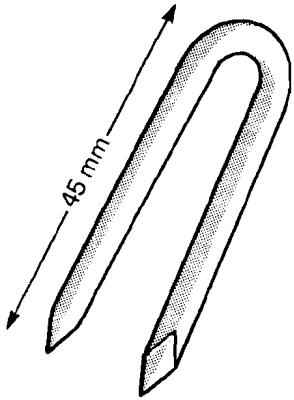

Fig. 6 Staple.

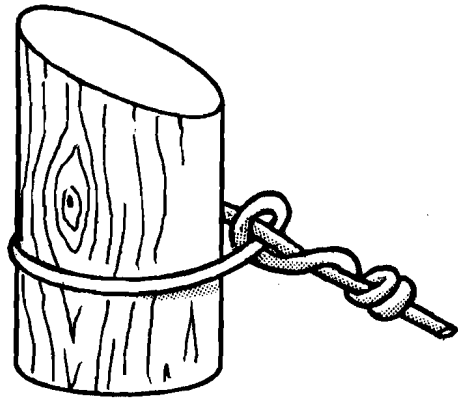

Fig. 7 Knot for tying off high-tensile wire.

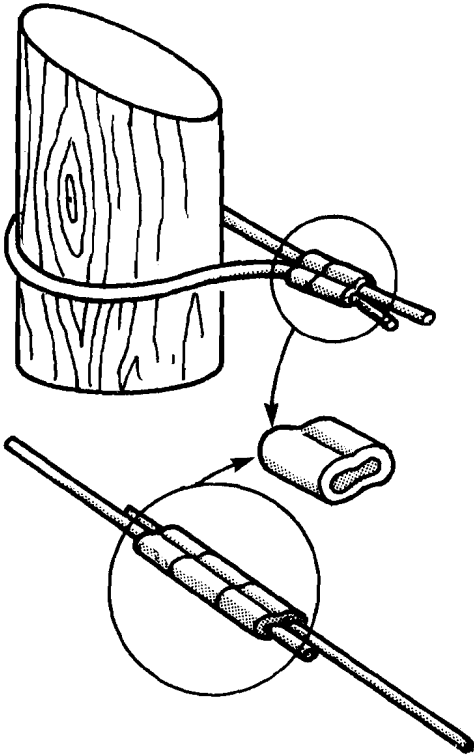

Fig. 8 Oval compression sleeves.

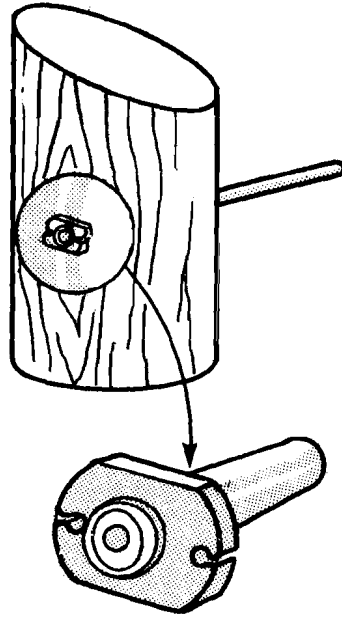

Fig. 9 Wirevise for high-tensile wire.

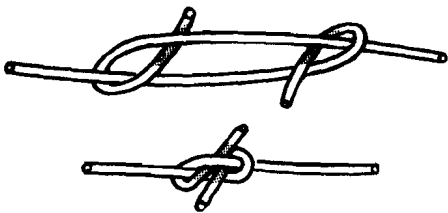

Fig. 10 Figure-eight knot for splicing high-tensile wire.



Fig. 11 Reliable Wirelink for high-tensile wire.

Knots

Barbed wire It is traditional to staple barbed wire tightly to brace and end posts, and to anchor the wire by double wrapping around the end post and fastening along the line wire by tightly twisting around the line wire. This works well if staples are driven snugly against the wire, but not so tightly that the wire is weakened or damaged. In high-tension fence, drive the staples on brace and end posts adjacent to the barbs, where possible, to prevent wire slippage in the direction of wire pull when the wire puller is released after tightening.

High-tensile wire This wire may also be tied off at end or brace posts with a special knot (Fig. 7) after stapling to brace and end posts. To tie this knot, allow about 76 cm of wire beyond the end post and wrap this around the post from the livestock pressure side. Passing the free end under the line wire, loop it back over the top of the line wire allowing several centimetres of clearance from the post. Pass the free end between the loop wire and the post, and pull, snugging the loop tightly against the post. Secure the free end to the line wire with pigtail wraps starting over the line wire.

Mechanical fasteners

Compression sleeves These sleeves may be used to tie wire off at end posts and braces (Fig. 8). Tests show that these fasteners retain 100% of the strength of the wire when properly installed. To use compression sleeves, leave about 60 cm of wire beyond the post. Before stapling, thread two or three oval sleeves onto the wire. Slide these back beyond the post. Wrap the wire around the post from the livestock pressure side and thread the free end through the compression sleeves. Position the sleeves a few centimetres from the post and double crimp each sleeve with a swager (described under "Tools").

Wirevise Another method of securing high-tensile wire to end posts is with a Wirevise (Fig. 9). Drill a 9.5-mm hole through the end posts, at the desired wire height, at a slight angle away from the livestock side of the fence. Thread the wire through both the hole and the Wirevise. Slide the Wirevise forward and embed it into the hole. The Wirevise will clinch the wire when reverse tension is applied and will be flush with the post. Cut surplus wire off flush with the fitting. This fastener is effective to 100% of the strength of the wire.

WIRE SPLICERS

Wire may be spliced with knots, which are generally effective to 60% of the strength of the wire, or with mechanical fasteners. Mechanical fasteners are effective to 100% of the wire strength when installed properly.

Knots

Barbed wire The most common method of splicing barbed wire is to form about an 8-cm loop by bending one end of the wire back along itself and securing by wrapping tightly around the line wire. Thread the free end of the joining wire through the loop and bend it back along itself to form a similar loop secured by wrapping tightly around the line wire.

High-tensile wire The knot most often used to splice this wire forms a figure eight (Fig. 10). To tie this knot, overlap about 20 cm of the ends of the wires to be spliced and bend a loop in the end of each around the other wire so that the loops are in opposite directions. Bring the end of the wire in each loop under itself so that the ends are pointing in opposite directions. Pull the loops tightly together. After the wire is tightened, remove excess wire.

Mechanical fasteners

Compression sleeves These can be used to splice wire as well as to tie off wire at end posts (Fig. 8). Thread the ends of both wires through the sleeves. Double crimp each sleeve with a swager to complete the splice. Compression sleeves are effective to 100% of the breaking strength of the wire.

Wirelink A Wirelink is available that will butt-splice high-tensile wire by simply inserting both wires as far as possible into the ends of the fixture (Fig. 11). Pulling in the opposite direction locks the wire, giving 100% of the breaking strength of the wire.

IN-LINE STRAINERS AND TENSION SPRINGS

Other items available for high-tensile fencing include adjustable in-line wire strainers with removable handles and in-line tension-indicator springs (Fig. 12). Both are permanent in-line fixtures in each span of fence, so use one type unless other means are used to tension the fence wires. One ratcheted wire strainer per wire will allow a manager to tighten or relax the wire in relation to temperature. Their use provides an easy and efficient way of retaining correct tension in line wires. They also facilitate quick repairs and retightening should the fence break.

Permanent installation of at least one tension-indicator spring on one wire of each span of fence allows the remaining wires of each span to be tensioned by finger tuning to the first wire. With practice this method is remarkably accurate.

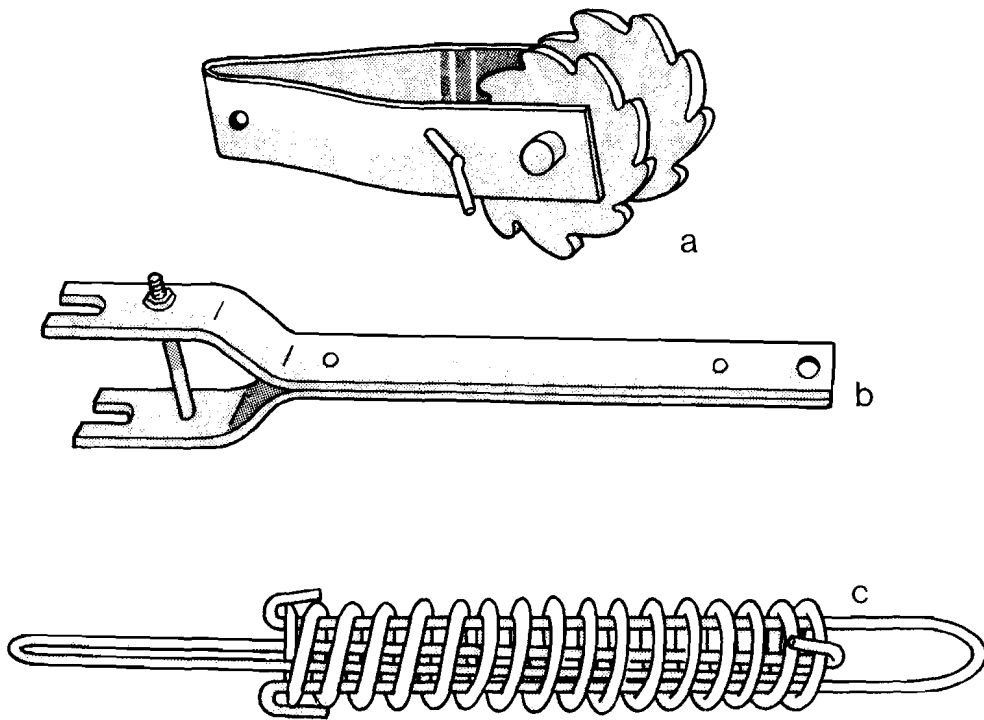

Fig. 12 (a) In-line wire strainer, (b) handle, and (c) tension-indicator spring.

TOOLS

All forms of construction require an assortment of tools designed to do specific jobs. Few things are more frustrating than not having a needed tool or having a poorly designed tool that does not work properly. In erecting high-tension fences the job requires the use of certain special and common tools.

Special tools

The following special tools are shown in Fig. 13:

- a Wire benders—hand fabricated of metal to work with high-tensile wire. A small pair of vise-grip pliers works well too.
- b Post-hole auger.
- c Wire sheaves—constructed of 13-mm plywood, these consist of aluminum rollers, either adjustable or fixed, and a means of temporary attachment to line posts. They function in spacing line wires parallel to the ground when placing tension on a fence. For high-tensile fences, spikes can replace the rollers, or the wire can be prestapled because there are no barbs to hang up. A number of these will be needed depending on the terrain.
- d Hand swagers—crimping pliers for compression sleeves. These are available commercially or can be fabricated from a pair of 450-mm bolt cutters with an 8-mm capacity. Drill a 9.5-mm

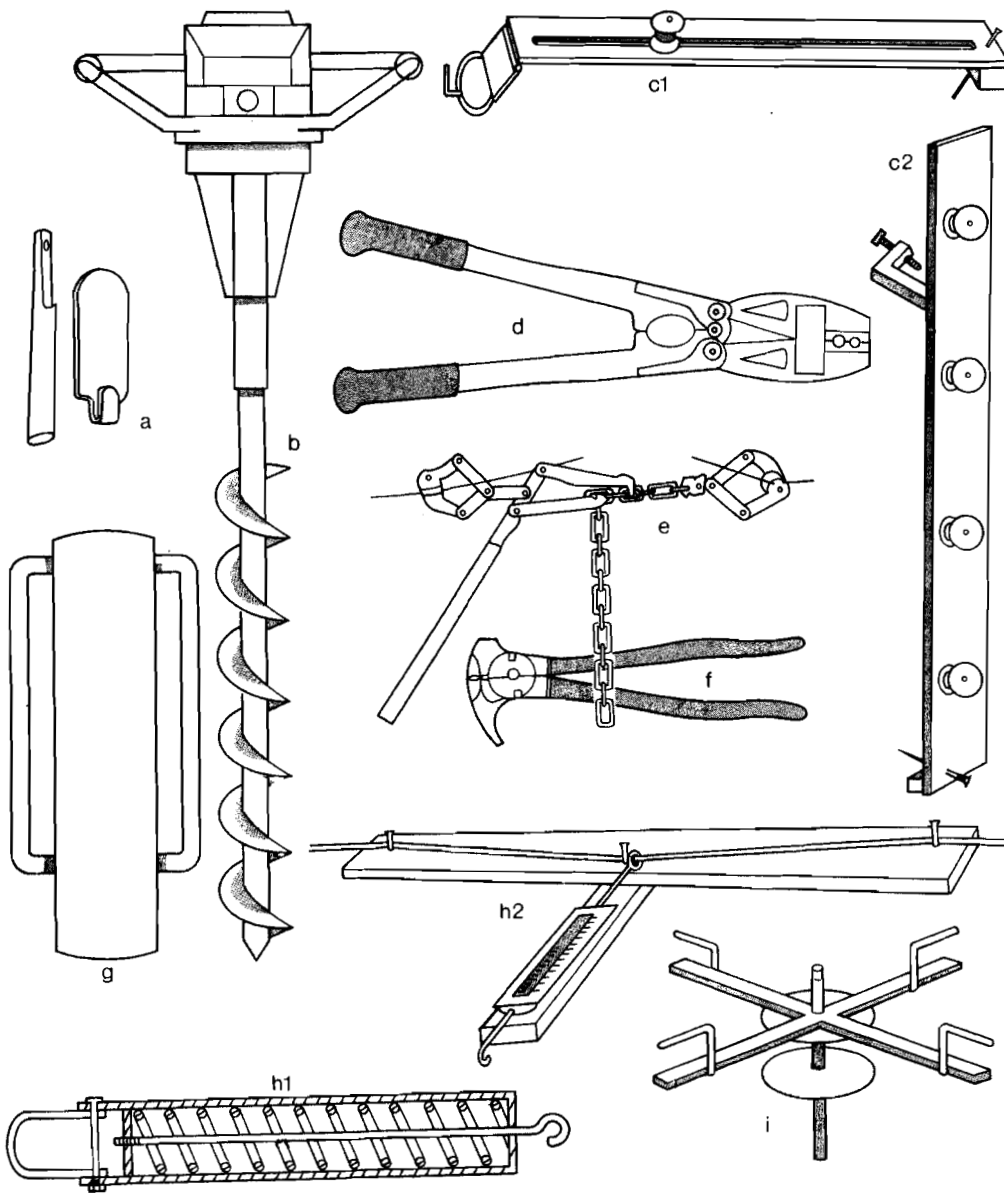

Fig. 13 Special fencing tools.

hole to crimp a 3.97-mm oval sleeve that accepts barbed wire. Drill a 6.35-mm hole to crimp a 2.38-mm oval sleeve that accepts high-tensile smooth wire.

- e* Wire pullers—these should have smooth jaws to protect the galvanized surface if working with high-tensile wire.
- f* Fencing pliers.
- g* Two-person post pounder.
- h* Tensionmeters
 - h1* consists of a compression spring installed inside a pipe. A graduated 8- or 9.5-mm plunger is attached to pass through the spring so a pull on both ends compresses the spring. One spring that works well compresses 15 mm for every 45.4 kg of load applied up to 272 kg. Other springs will work as well if calibrated.
 - h2* consists of a straight piece of 20 × 50 mm board 107 cm long. Drive two nails on a straight line 102 cm apart at the ends of the board. At the middle of the board drive a third nail 13 mm below the line joining the end nails. Tension is measured by pulling the fence line wire to just touch the centre nail and multiplying the scale reading by 20.
- i* Wire reel.

Common tools

The following common tools are shown in Fig. 14:

- a* Notched marking stick.
- b* 25-cm crescent wrench.
- c* 12.7-mm electric drill.
- d* Claw hammer.
- e* Hand brace and 9.5 × 200 mm bit.
- f* Saw.
- g* Plumb bob.
- h* 18-m chain or tape.

PLANNING THE FENCE

BOUNDARIES

Whether your fence will divide properties, follow terrain contours, or facilitate cattle movement on your range, you must establish boundaries. It is often advantageous to have a surveyor determine property bounds before building perimeter fences. Then, if it is desirable to fence on contours to facilitate cattle movement, strike an agreement between neighbors. Remember, however, that the fence may outlast the neighbor.

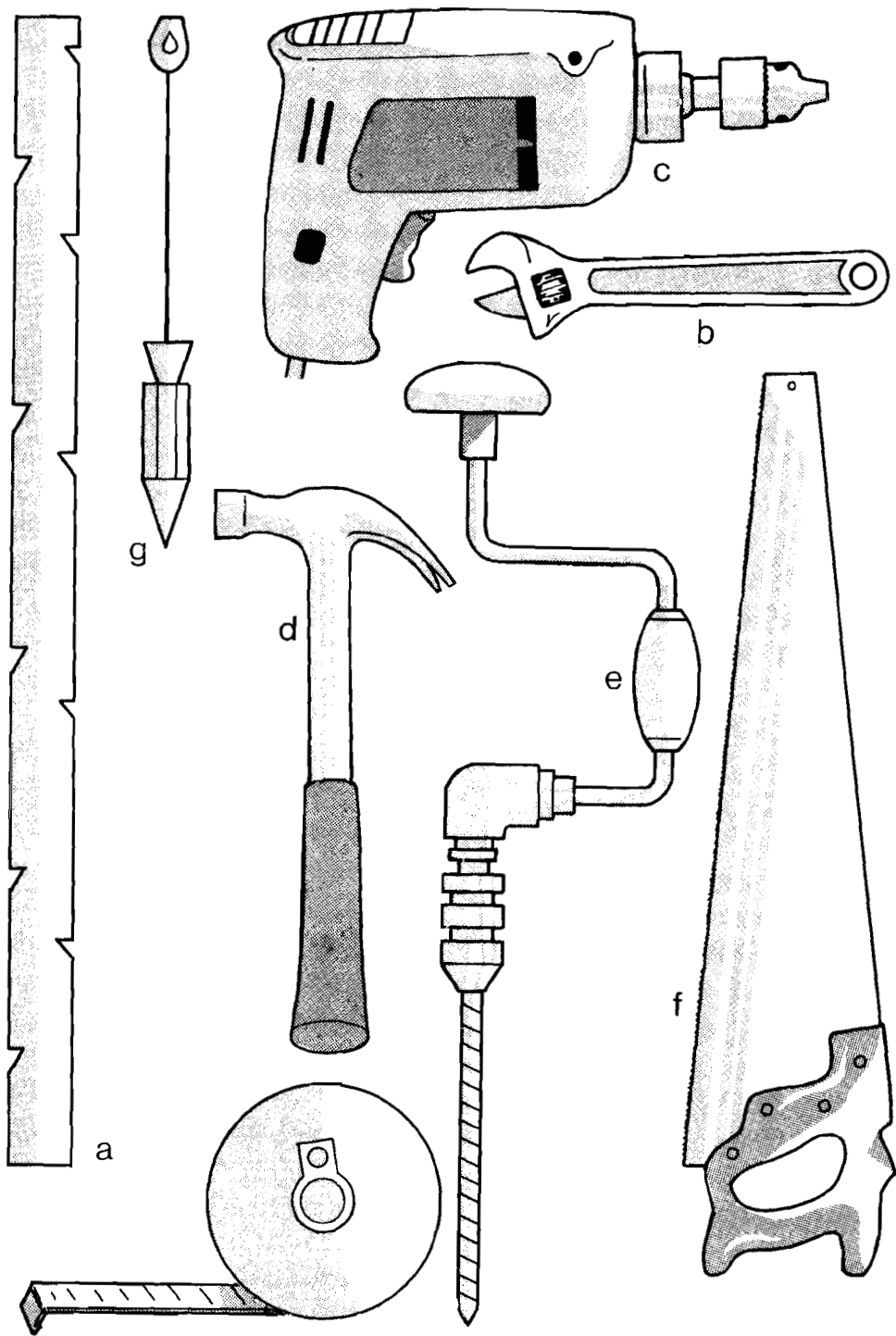

Fig. 14 Common fencing tools.

LAWS

Check local laws to be certain that the fence you plan will legally meet your specifications and requirements. Your district agriculturist should be able to provide this information.

HAZARDS

Locate hazards or constraints such as bogs, embankments, flooding, deep snow drifting, highways, railways, mining, and recreation areas. Provide special fencing for these areas if necessary. Check with electrical, telephone, water, gas, and sewer authorities to determine possible buried lines and easements that may exist.

TERRAIN

Check your topography. Fencing in hilly areas and on curves can present special problems that require special construction techniques and materials. Remember that all wires on any fence should be parallel to the ground, which may require some grading or special fence assemblies.

SOILS

Check your soil. Soils can greatly affect the materials and methods of fencing. Generally, however, whether your soil is soft, medium, or hard clay, or is sandy, the best method of setting posts is by driving. Tests have shown that the force required to pull a driven post can be 10 times greater than that of a post set by digging, backfilling, and tamping. Driving posts in hard soils may require preaugered holes in which to drive the post, but it may be worth the extra effort. Similarly, some situations may require a deadman be anchored in the bottom of a hole to hold a post in place (Table 2).

PERFORMANCE

Consider what you expect of the fence. For example, a fence that is well designed for cattle on the open range may be ineffective in containing calves or yearlings in a confined pasture. Usually, perimeter or boundary fences must be more secure and versatile than division fences. Perimeter fences must often contain more than one kind of livestock, protect crops, or turn away wildlife. Your plans and a knowledge of animal behavior will be helpful in designing the fence.

LOCATION

Design fences so they are more than dividing barriers. Fences can also aid in livestock management by allowing efficient movement of

livestock, easy access to water, increased use of forage, and ease of movement of livestock and of farm machinery.

PREPLAN

Sketch your layout to include everything that can influence materials or construction, such as fence dimensions, corners, angles at change of direction, gate locations and widths, and rises and dips. From this sketch, itemize the materials that will be required, such as the number of posts, amount of wire, staples, fasteners, and other hardware. Further, the costs involved can be estimated more accurately before the job is started.

SPECIFICATIONS

High-tension fences are versatile and it is possible to select a design for practically any requirement or set of requirements. These fences can be easily modified by adding or removing wires. Smooth high-tensile wire fences can also be electrified. Many fences are overdesigned for their intended purpose. Although these fences may produce additional safety, the extra materials and labor involved may nullify any benefit gained. Gates in range and pasture fences are usually of wire and are attached to the end posts. Following are specifications for several fence designs.

FOUR-WIRE BARBED-WIRE RANGE FENCE

This design is adequate for cattle on range where there is not unusual crowding to force calves against the fence. It allows wildlife to move freely by crawling under, or jumping the fence. The 101-cm fence is used in areas of high deer traffic. Cattle, particularly bulls, may attempt to jump low fences.

Height of top wire:	101 or 116 cm
Wire spacing from ground up	
116-cm fence:	38, 25, 25, and 28 cm
101-cm fence:	38, 20, 20, and 23 cm
End posts	
length and diameter:	244 cm × 152 mm
driven depth:	122 cm
Brace posts	
length and diameter:	244 cm × 101 mm
driven depth:	122 cm
Top braces	
length and diameter:	244 cm × 101 mm

Line posts	
length and diameter:	200 cm × 76 mm
driven depth:	76 cm
Post spacings:	18.5 m
Droppers:	metal snap-on or wood
Dropper spacing:	3 m
Tension per wire:	Tension barbed wire to 270 kg to remove kinks; then relax tension and fasten at 136 kg at 0°C or equivalent, to gain elasticity.

FIVE-WIRE RANGE FENCE

The five-wire high-tensile fence is a range fence replacing the four-wire barbed-wire fence. It is a fence for light livestock pressure. The five-wire barbed-wire fence is a fence for medium-to-heavy livestock pressure.

Height of top wire:	114 cm
Wire spacing from ground up	
barbed wire:	31, 20, 20, 20, and 23 cm
high-tensile wire:	40, 18, 18, 18, and 20 cm
End posts	
length and diameter:	244 cm × 152 mm
driven depth:	122 cm
Brace posts	
length and diameter:	244 cm × 101 mm
driven depth:	122 cm
Top brace	
length and diameter:	244 cm × 101 mm
Line post	
length and diameter:	240 cm × 76 mm
driven depth:	76 cm
Post spacings:	up to 18.5 m.
Droppers:	galvanized metal snap-on or wood
Dropper spacing	
light grazing pressure:	4.6 m
moderate-to-heavy grazing pressure:	3 m
Tension per wire	
barbed wire:	Set to 270 kg to remove kinks; then relax tension and fasten at 136 kg at 0°C or equivalent to gain elasticity.
high-tensile wire:	136 kg at 0°C or equivalent.

SIX-WIRE HIGH-TENSILE LIVESTOCK FENCE

This fence replaces the four- or five-wire barbed-wire fence. It is designed primarily for light-to-moderate livestock pressure by large animals.

Height of top wire:	116 cm
Wire spacing from ground up:	33, 15, 15, 15, 18, and 20 cm
End posts	
length and diameter:	244 cm × 152 mm
driven depth:	122 cm
Brace posts	
length and diameter:	244 cm × 101 mm
driven depth:	122 cm
Top braces	
length and diameter:	244 cm × 101 mm
Line posts	
length and diameter	
(minimum):	200 cm × 76 mm
driven depth:	76 cm
Post spacings:	up to 18.5 m
Droppers:	galvanized metal snap-on or wood
Dropper spacing	
light grazing pressure:	4.6 m
moderate grazing pressure:	3 m
Tension per wire:	136 kg at 0°C or equivalent.

EIGHT-WIRE HIGH-TENSILE LIVESTOCK FENCE

This fence will contain both small and large animals on range and will discourage some wildlife and dogs.

Height of top wire:	117 cm
Wire spacing from ground up:	10, 13, 13, 13, 15, 15, 18, and 20 cm
End posts	
length and diameter:	244 cm × 152 mm
driven depth:	122 cm
Brace posts	
length and diameter:	244 cm × 101 mm
driven depth:	122 cm
Top braces	
length and diameter:	244 cm × 101 mm
Line posts	
length and diameter:	200 cm × 76 mm
driven depth:	76 cm
Post spacings:	up to 18.5 m

Droppers:	galvanized steel snap-on or wood
Dropper spacing	
light grazing:	4.6 m
moderate grazing:	3 m
heavy grazing pressure:	1.5 m
Tension per wire:	136 kg at 0°C or equivalent.

TEN-WIRE HIGH-TENSILE LIVESTOCK FENCE

This fence can contain most kinds of livestock, can turn away many small domestic or wild animals, and may be used to replace woven wire. It is a deterrent to carnivores, especially if the second, fourth, and top wires are electrified.

Height of top wire:	118 cm
Wire spacing from ground up:	10, 10, 10, 10, 13, 13, 13, 13, 13, and 13 cm
End posts	
length and diameter:	244 cm × 152 mm
driven depth:	122 cm
Brace posts	
length and diameter:	244 cm × 101 mm
driven depth:	122 cm
Top braces	
length and diameter:	244 cm × 101 mm
Line posts	
length and diameter:	200 cm × 76 mm
driven depth:	76 cm
Post spacings:	up to 18.5 m
Droppers:	galvanized steel snap-on or wood
Dropper spacing	
light pressure:	4.5 m
moderate livestock pressure:	3 m
heavy livestock pressure:	1.5 m
Minimum tension per wire:	136 kg at 0°C or equivalent.

Caution: Do not use metal droppers on electrified fence.

TEN-WIRE HIGH-TENSILE CATTLE FEEDLOT FENCE

This design differs from other high-tensile designs because of the increased livestock pressure. In this design, posts are either drilled for the passage of wires or are staggered on alternate sides of the wire if livestock pressure is likely on both sides of the fence. Gates are of heavy metal or wood and may or may not be part of a brace assembly.

Height of top of wire:	133 cm
Wire spacing from ground up:	25, 10, 10, 10, 13, 13, 13, 13, and 13 cm
Gate posts	
length and diameter:	244 cm × 152 mm
driven depth:	107 cm
End posts	
length and diameter:	244 cm × 152 mm
driven depth:	107 cm
Brace posts	
length and diameter:	244 cm × 127 mm
driven depth:	107 cm
Top braces	
length and diameter:	244 cm × 101 mm
Line posts	
length and diameter:	244 cm × 101 mm
driven depth:	107 cm
Post spacings:	3-m centres
Staples:	45 mm galvanized, slash points (not needed if posts are drilled)
Tension devices:	One in-line wire strainer per wire
Wire splices:	Three crimped sleeves or Wirelinks
Tension per wire:	136 kg at 0°C or equivalent.

TWELVE-WIRE HIGH-TENSILE HORSE FENCE

This fence will secure full-grown horses and foals, while deterring small animals. The top and bottom wires can be electrified to discourage horses from pawing and reaching over the fence.

On high fences it may be necessary to drive posts that are too long to be driven by a hydraulic ram. In these instances, hand-plant the post by augering and backfill to a depth that will allow driving with the ram. Then drive the post to the specified depth.

Height of top wire:	146 cm
Wire spacing from ground up:	10, 10, 10, 10, 13, 13, 13, 13, 13, 13, 13, and 15 cm
Gate posts	
length and diameter:	274 cm × 152 mm
driven depth:	122 cm
End posts	
length and diameter:	174 cm × 152 mm
driven depth:	122 cm
Brace posts	
length and diameter:	274 cm × 127 mm
driven depth:	122 cm

Top braces	
length and diameter:	274 cm × 101 mm
Line posts	
length and diameter:	244 cm × 101 mm
driven depth:	91 cm
Post spacings:	4.3 m centres
Staples:	45 mm galvanized, slash points
Wire splices:	Three crimped sleeves, Wirelinks
Tension per wire:	136 kg at 0°C or equivalent.

LAYING OUT

ACROSS LEVEL TERRAIN

Locate survey pins or stakes at ends of line and stand sighting poles a few centimetres beyond where the beginning and end of the fence will be. Place one or more intermediate poles and align all poles by sighting over the starting pole to the end pole (Fig. 15).

OVER UNEVEN TERRAIN

Rises or dips in the sighting line require the use of special techniques. For a rise, set two sighting poles about 3 m apart at the top of the rise, so that both can be seen from either end of the fence (Fig. 16). When crossing a dip, place two poles and align these by sighting from the highest point on both sides of the dip (Fig. 17).

AROUND CURVES

Running high-tension wires around curves and corners without constructing brace assemblies is possible, but extra care is necessary. Measure the exact location of posts and use larger-sized posts as needed. Drive posts deeper and at a 10-cm lean off vertical toward the outside of the curve to allow for movement when tension is placed on the wires. On sharp curves, reduce post spacings and staple all wires on the outside of all posts in curves. The section on "Construction" gives directions on rounding corners.

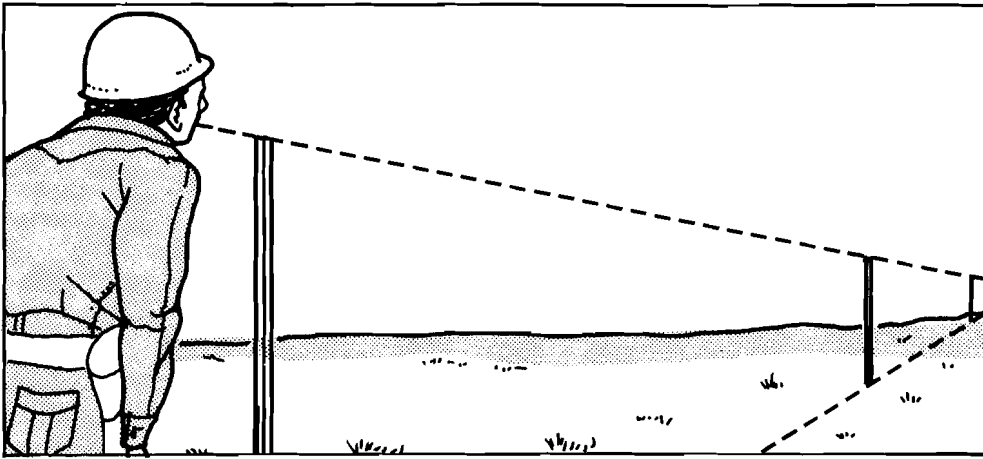

Fig. 15 Sighting a fenceline on level terrain.

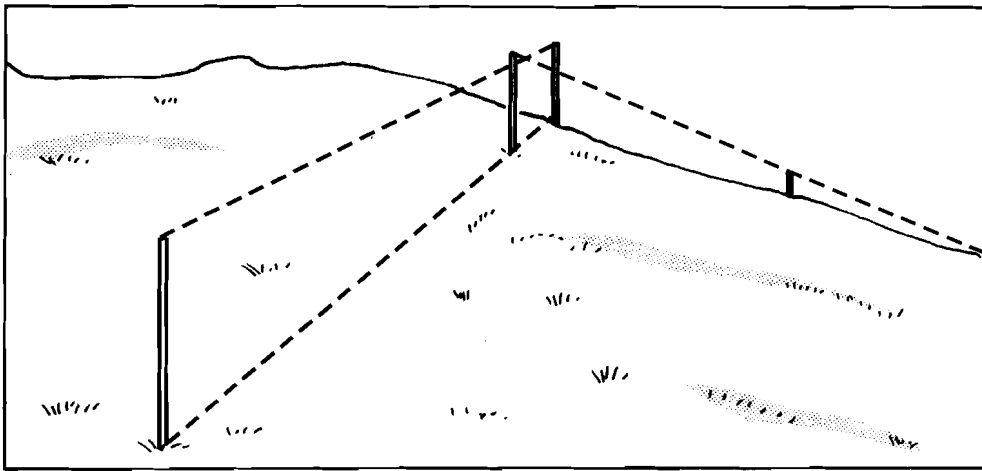

Fig. 16 Sighting a fenceline over rises.

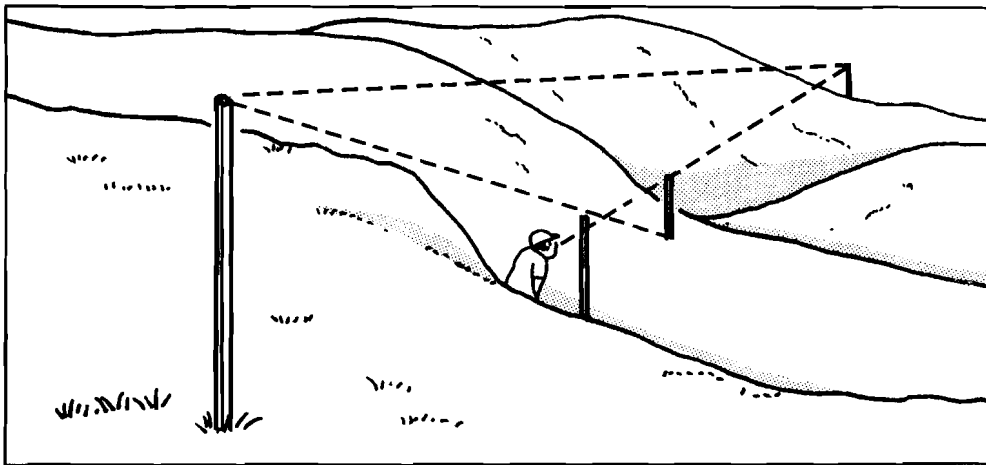

Fig. 17 Sighting a fenceline through dips.

CONSTRUCTION

CLEARING THE LINE

Remove all obstacles that will interfere with fence construction, including small brush and tall grass. If possible, level the fencerow. These practices will greatly reduce problems with construction and will result in a straighter fence that is easier to maintain.

PLACING END, CORNER, AND GATE POSTS

Each section of high-tension fence begins and ends at either an end post, brace post, or gate post. Thus the location and placement of these posts are the most important factors in how your fence turns out. They provide the anchors for the fence and are the first members of brace assemblies, which must withstand the tension of the wire. The procedure for setting these posts is as follows:

1. Select a straight, 244-cm long post of proper diameter. Mark the exact location where it is to be placed and auger a pilot hole 90 cm deep and smaller in diameter than the post. Auger this hole so that the top of the post will lean 50 mm off vertical opposite the direction of pull of the line wires (Fig. 18). Posts can be driven in some soils without augering pilot holes.
2. Drive the post to a depth of 122 cm. Some soils may be particularly loose (such as bogs) in which case strengthen posts if possible by placing deadman anchors (Fig. 19). Each anchor is constructed from a short (30-cm) piece of 10×10 cm treated post. Cut one end of this on a 45° angle and fasten a cable (made from

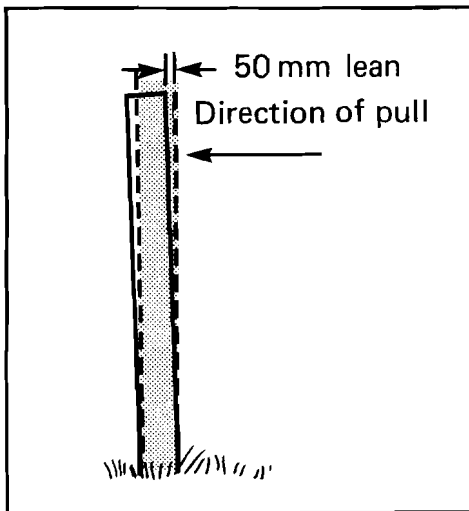

Fig. 18 Proper placement of end posts.

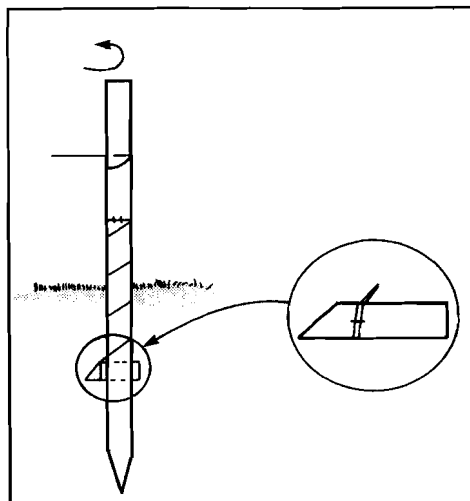

Fig. 19 Deadman anchor to prevent excessive twisting of end post.

twisting wire together) securely to it, about 10 cm back from the diagonal end. Enlarge one side of the bottom of the augered hole, jam the anchor in and pull it taut, forcing the anchor to a position parallel to the soil surface. Drive the post past the anchor and attach the cable to the post in the same direction as any twist that will be placed on the post by the line wires.

3. Proceed using steps 1 and 2 until all end posts are driven.

It may be necessary to drive posts that are too long to fit under the ram of a post pounder. In these situations, auger a hole and set the post by backfilling and tamping to depth such that the post can be driven to the full specified depth using the post pounder.

STRINGING THE GUIDE WIRE

Proper stringing of the guide wire is the key not only to a straight fence but also to one that has all wires parallel to the soil surface. The procedure for stringing the wire differs depending on whether the fenceline crosses level or uneven terrain or rounds curves.

Level terrain

1. Either anchor the wire reel or tie off the free end of the wire on the end post at the desired height for the bottom wire. If wire is tied off, use a portable reel for paying out wire.
2. Pay out the wire, using the wire reel to avoid kinking the wire, in a straight line to the far end post. Maintain enough tension to prevent loops or recoils of slack wire.
3. Proceed about 90 cm past the end post, attach a wire puller to the free end of the wire and pull it up until taut (about 45-kg tension).
Note: It is desirable that wire pullers have smooth jaws to prevent damaging galvanization of the wire.
4. Make sure the wire is straight between the posts. Whip the wire up and down or add more tension to accomplish this.
5. Wrap the wire from the livestock pressure side and secure the wire back onto itself at the premarked height of the bottom wire. Temporarily tie off with either an end post tie-off knot, a crimped sleeve, or with a Wirevise (see section on "End-post fasteners").

Uneven terrain

1. Locate the guide wire by either using the sighting poles or by driving permanent posts at the top of rises. If permanent posts are used, take care in post location (use sighting poles) and in the size of post used in relation to its ultimate function as part of the finished fence.
2. Pay out the wire on the livestock pressure side of the fenceline. Attach a wire puller to the wire and tighten the wire to 45 kg. If permanent posts have been driven, use wire sheaves (Fig. 13c) to

guide the wire. If the sighting poles are used, take care in relation to the terrain. In the case of high points, the wire will rest on the ground; it will bridge the dips.

3. If wire is on the ground, raise and whip it up and down at the highest point on each rise to get it straight and touching the sighting poles. Mark locations for driving rise posts.

Note: When driving posts, ensure that they are 13 mm off the guide wire to maintain a straight fence.

4. Drive rise posts, attach wire sheaves or staple smooth wire at desired height for bottom wire (see section on "Stapling").
5. Near the sighting poles in each dip, mark the locations for dip posts either by using a plumb bob (Fig. 20) if you can reach the guide wire, or by sighting using the sighting poles (Fig. 17).
6. Drive a 244-cm post to a depth of 122 cm at the location of each dip post.
7. Reduce the tension on the guide wire sufficient to pull it down to the bottom wire height on the dip posts. Use wire sheaves or staple smooth wire to guide the wire. Retighten the wire to 45 kg.
Note: An alternate method of handling large dips is to allow the fenceline to bridge the dip permanently (Fig. 21). This practice does not necessitate lowering the guide wire into the dip as discussed above, nor does it require longer dip posts. Fasten a short span of fence in the dip to the fenceline posts proper but do not tighten it to 136 kg tension.

Curves

Set line posts in curves before stringing the guide wire using one of the following techniques.

Rounding shallow curves For change of direction less than 20 degrees (Fig. 22), proceed as follows:

1. Set two short stakes (A and B) on the fenceline at the beginning and end of the curve.
2. Stretch string between stakes A and B.
3. Mark the mid point (C') and measure the perpendicular distance to what would be the fenceline (C) had it continued in a straight line from stake A.
4. a) If the distance in step 3 is less than 61 cm, drive a 244 cm × 100 mm post 122 cm deep at the point (C) of intersection with the original fenceline.
b) If the distance in step 3 is from 61 cm to 122 cm, drive a 244 cm × 127 mm post at point C.
c) If the distance in step 3 is from 122 cm to 178 cm, drive a 244 cm × 152 mm post at point C.

Note: Drive the post at a slant of 10 cm off perpendicular toward the outside of the curve. On fences with less than seven wires, the diameter of posts can be reduced by 25 mm.

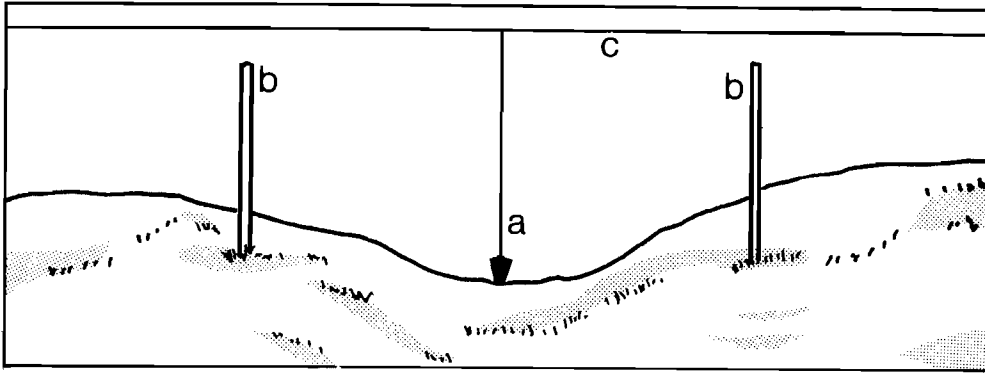

Fig. 20 Use of plumb bob for locating post position in dips: (a) plumb bob, (b) sighting pole, and (c) guide wire.

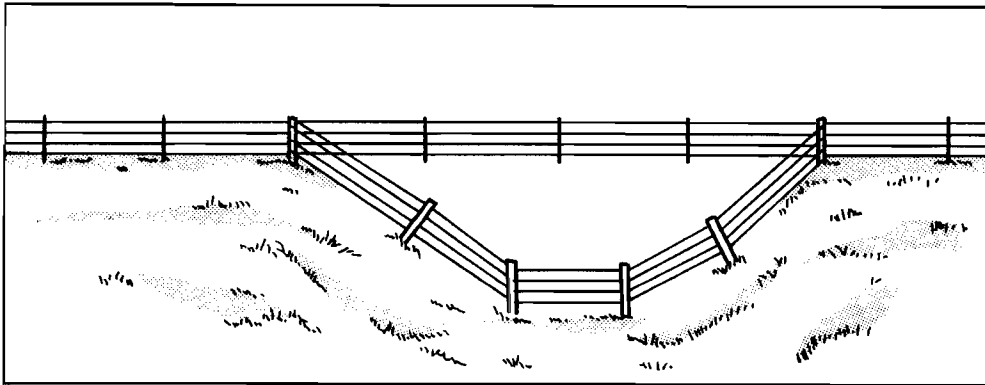

Fig. 21 Bridging a narrow gully with high-tension fence.

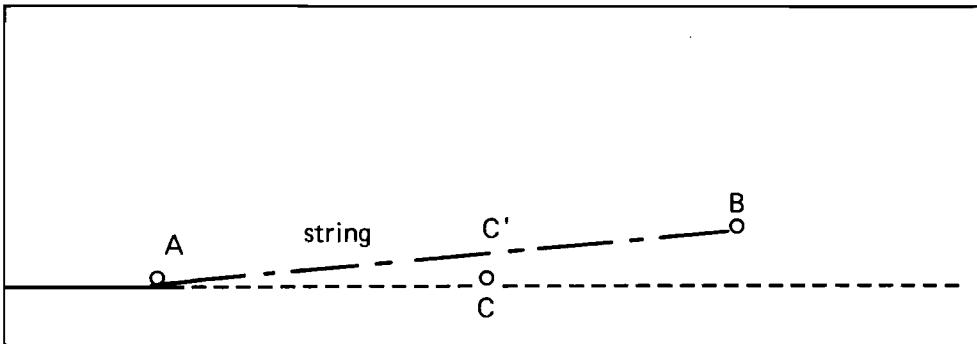

Fig. 22 Rounding a shallow one-post curve.

Rounding a long, gradual curve This technique is a continuation of that using one-post to round a shallow curve (Fig. 23). Determine the position of each post from the previously set curve post and drive each 10 cm off the perpendicular to allow for movement when the wires are tensioned. Posts will be at A, C, B, D, and so on as already described.

Rounding a sharp corner or curve Rounding a sharp corner is similar to rounding a shallow corner or curve, but all posts are 244 cm × 152 mm and lean 101 mm toward the outside (Fig. 24). Reduce the post spacing to fit the curve radius. However, do not set posts less than 122 cm apart to maintain soil stability.

Note: Use caution when tensioning wire around curves to ensure wire (especially barbed wire) does not hang up on the post.

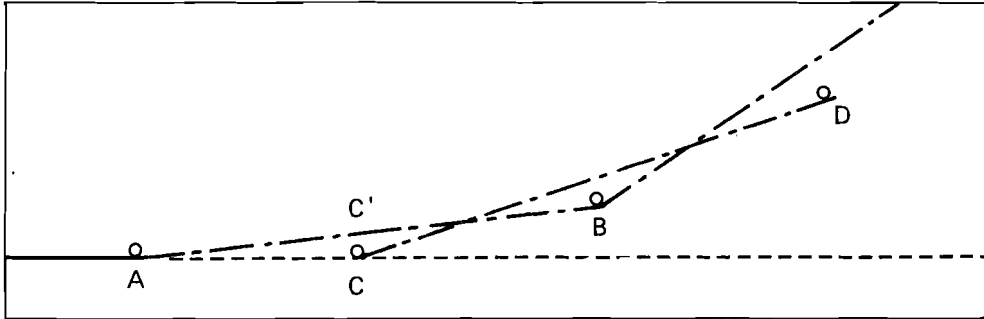

Fig. 23 Rounding a long, gradual corner or curve.

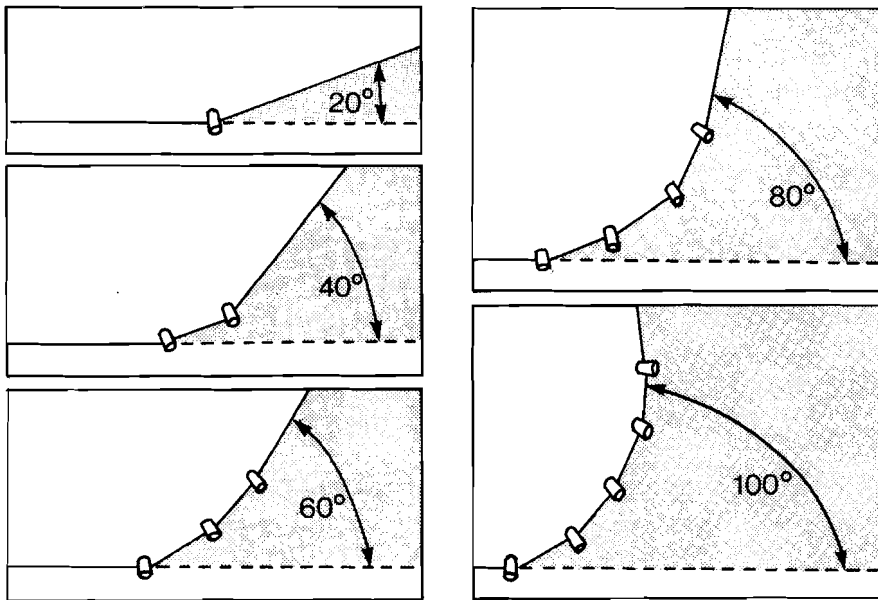

Fig. 24 Rounding a sharp corner or curve.

CONSTRUCTING BRACE ASSEMBLIES

Construct braces at corners and ends of fences, at gates, and in the fenceline at appreciable changes in slope of the terrain. Space braces generally not more than 400 m apart. Use posts in brace assemblies of

at least 244 cm × 123 mm and drive them at least 122 cm deep. For all diagonals on braces use at least 12-1/2 gage wire, double or triple wrapped to prevent breakage. Construct all joints carefully using either dowel pins or spikes as fasteners. Use dowel pins that are corrosion resistant and spikes that are at least 89 mm longer than the post diameter. Tighten line wires and fasten them securely to the end post of the brace so that the pull is through the brace. Then fasten them snugly to the first and second braceposts.

Construction details

Shown here are construction details for type 3 braces (Fig. 3). These braces are easiest to build (less exacting) and are sufficiently strong for all fences, of 12 or fewer wires, described in this bulletin. However, where high stress is anticipated and with fences of 7 or more wires, use double brace assemblies for corner assemblies and end braces. Use double braces also either in cases where smaller posts are used, when posts are not driven a full 122 cm, or in loose or boggy soils. Figs. 25–33 show various brace assemblies.

Note: Inside brace assemblies, as shown in Figs. 30, 31, and 32, are subject to cattle rubbing on them in areas of moderate-to-high cattle pressure. Rubbing is undesirable and must be considered in construction if these braces are selected.

Construction procedure

Having driven the end posts, rise posts, corner posts, and gate posts and strung and tensioned the guide wire, use the following procedures to construct a type 3 brace.

1. Lay a 244 cm x 101 mm top brace on the ground parallel to the guide wire and butt it against the end post to measure the location for driving the first brace post. Holding the guide wire aside, drive the post 122 cm deep to establish a 2.5-cm lean opposite the direction of pull of the line wires.

Note 1: All post holes may require augering a 7-cm hole 90 cm deep.

Note 2: Allow 25 mm overlap for squaring of brace posts if spikes are used.

2. Again, holding the guide wire aside, measure with the second horizontal brace and drive the second brace post without any lean. When the guide wire is released it should just touch the posts.
3. If spiking, square the tops by removing not more than 13 mm of wood from the inside top of the brace and end posts and spike through the post into the ends of the horizontal brace.
4. If using pins, use the following procedure:
 - Measure up 118 cm from the ground on the brace side of the end post and drill a 9.5-mm hole 51 mm deep parallel to the line wires.

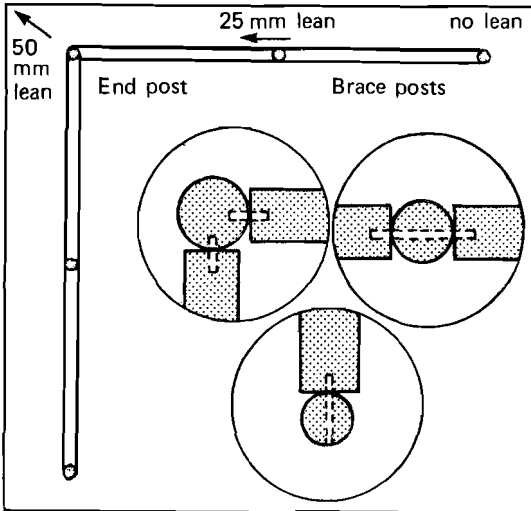

Fig. 25 Corner brace assembly showing joint detail using pins.

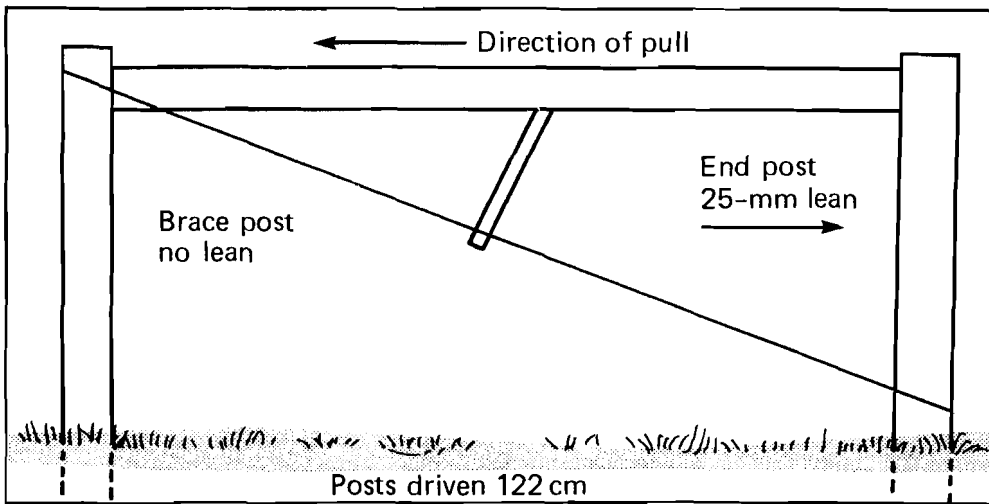

Fig. 26 Single-span brace assembly.

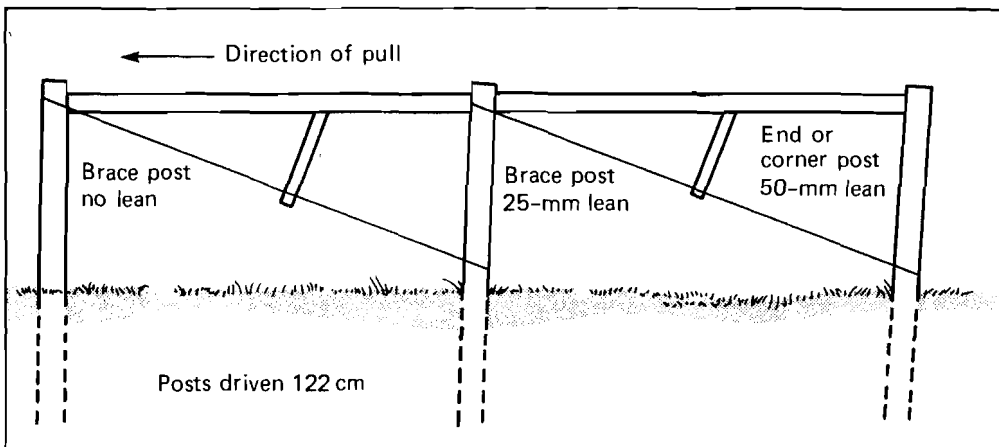

Fig. 27 Double-span brace assembly.

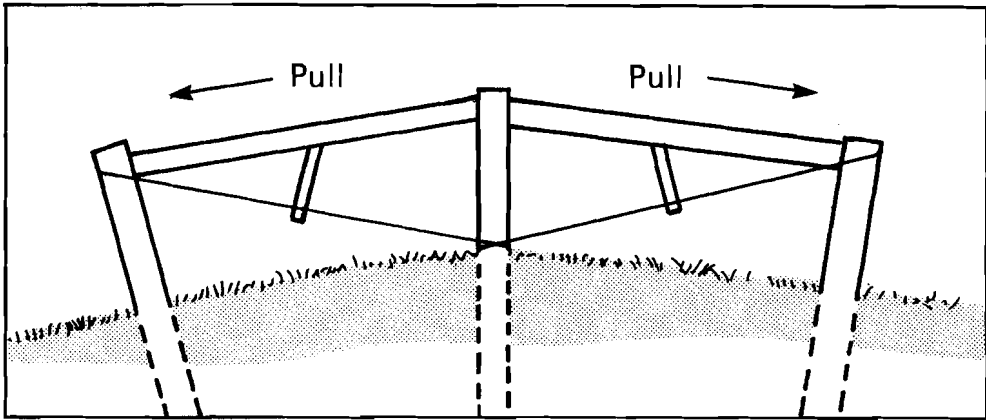

Fig. 28 Double brace assembly for rise posts.

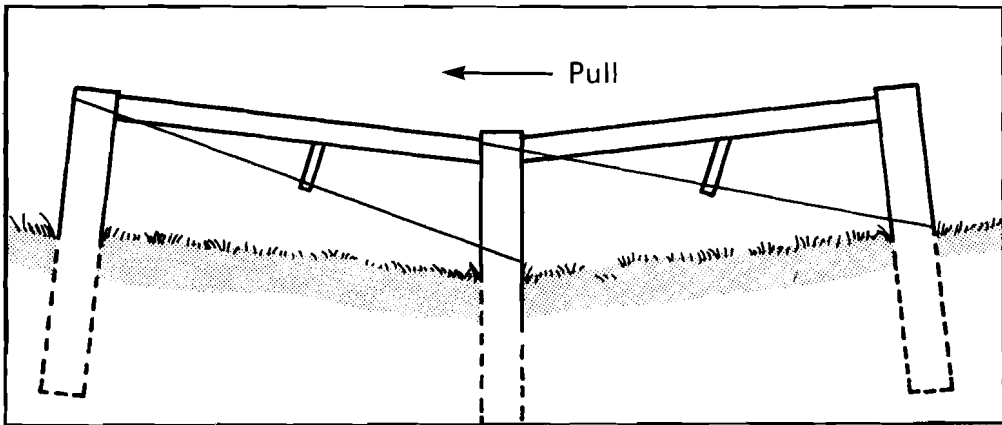

Fig. 29 Double-span dip assembly.

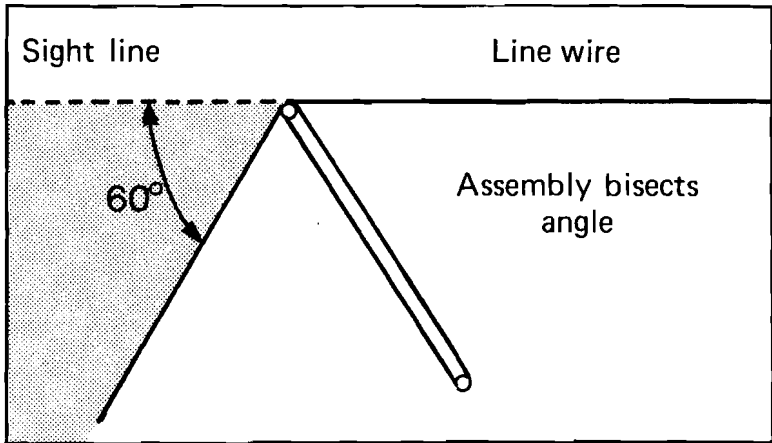

Fig. 30 Medium corner brace assembly for change of direction greater than 20° but less than 60°.

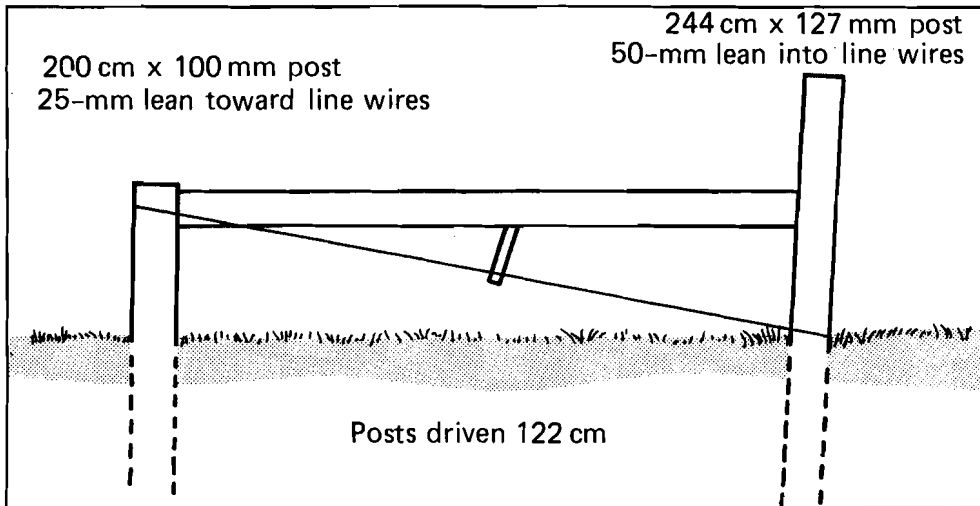

Fig. 31 Medium corner brace assembly (Fig. 30) showing construction.

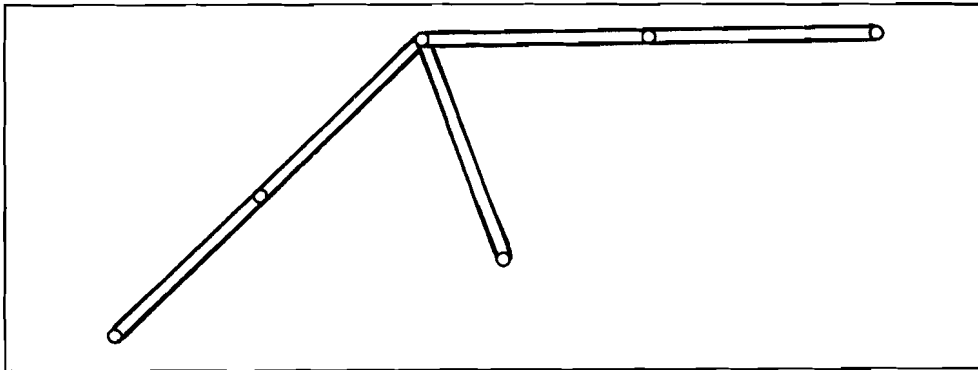

Fig. 32 Double brace assembly for shallow corner in soft or boggy soils.

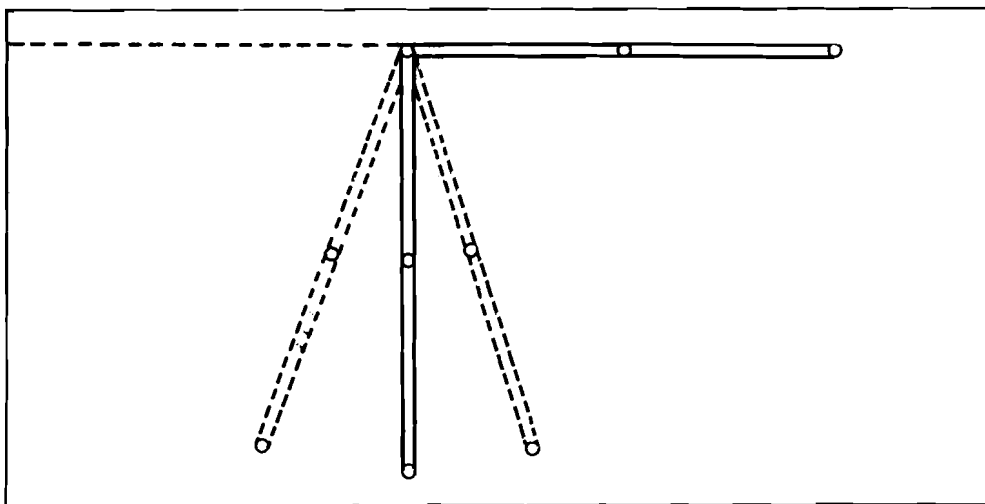

Fig. 33 Double brace assembly for angles greater than 60°.

- Drive a 9.5 × 100 mm galvanized-steel dowel pin 50 mm deep into the drilled hole in the end post.
 - Measure up the first brace post 118 cm and drill a 9.5-mm hole through the post parallel to the line wires.
 - Drive a 9.5 × 230 mm steel dowel pin through the post, stopping when the pin emerges flush with the post surface.
 - Mark, drill, and drive the pin in the second brace post similar to the first.
 - Drill a 9.5-mm diameter hole 51 mm deep in the centres of both ends of the horizontal top braces.
 - Lift the first horizontal brace and position it on the pin protruding from the end post, align it with the pin on the first brace post and drive the pin 51 mm into the first top brace leaving 51 mm of the pin protruding to receive the second top brace.
5. Cut a 12.1-m length of at least 12-1/2 gage fencing wire and bend a 15-cm loop in one end. Staple this loop or hook it over the protruding pin on the brace post. Maintaining hand tension on the wire, stretch a diagonal and wrap the wire around the end post under a horizontal staple and back over the pin or staple on the brace post. Complete two complete tight wraps in the same manner.
 6. Pull as much slack up as possible and staple the wire to the brace post.
 7. Facing the diagonal wires, opposite the livestock pressure side of the fence, insert a 38 mm × 50 mm × 60 cm, treated, twitch stick about 50 cm between the four diagonal wires, perpendicular to the wires so the end of the stick rests against the horizontal brace.
 8. Maintaining this length, tilt the stick toward the post so that the stick clears the top brace and pull the stick toward you to twist the wires together. Make six or eight complete revolutions twisting the wires and stopping with the stick in the upright position. Tilt the stick back so it rests against the top brace and cannot unwind.
 9. Cut a length of wire and staple it over the end of the twitch stick onto the top brace to secure the twitch stick.
 10. Bend the horizontal guide staples over the wire at the bottom of the end post and brace post to hold the wire.
 11. Install the second top brace similarly to the first one.
 12. Install diagonal wires similarly to the first one.

DRIVING LINE POSTS

Having set the end posts and strung the guide wire, use the following procedure to drive the line posts.

1. Measure the location of posts by pacing or by stretching a tape and marking the location of each post. Set posts 18 m apart on level terrain or as far apart as the terrain will allow (up to 18 m) to maintain the wires parallel to the ground on uneven terrain.

2. Lay out a 198 cm × 100 mm line post at each location for driving.
3. Drive each post perpendicular to the soil surface to a 76-cm depth to maintain a straight fence. Take care that posts do not push the guide wire out of alignment. It is a good practice to allow 13–20 mm clearance between the driven post and the guide wire.
4. On uneven terrain, take care to drive all posts perpendicular to the soil surface (Fig. 34). This action maintains maximum stability in the soil and maintains the fence height.
5. Generally set posts on the downhill side of the wire on fences running across a slope and on the side of wire opposite the greater livestock pressure for more level situations.

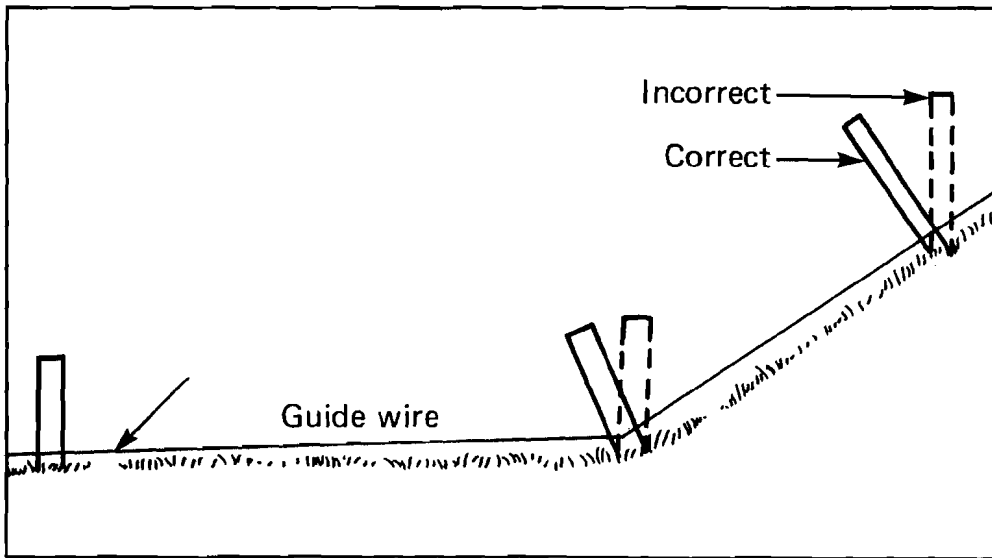

Fig. 34 Vertical placement of line posts.

STRINGING LINE WIRES

There are special considerations to make when working with wire. Barbed wire has barbs that catch and tear clothes and flesh, and it will recoil when cut. High-tensile wire is stiffer, is harder to bend, and has a greater tendency to recoil than barbed wire. To cut wire, hold the needed end in one hand and step on the other end. If you must release a cut end secure it with something or push it several centimetres into the soil. Wear clothing that completely covers your arms and legs, heavy soled shoes, leather gloves, and safety glasses.

The nature of barbed wire practically dictates that wires be strung one at a time to avoid tangling. Because smooth, high-tensile wire does not tangle, it is possible to string all wires at the same time.

To String Wire

Use the following procedure to string wires:

1. Load wire onto payout reels and, beginning at end post position, on the livestock pressure side of the posts either tie off the wires beginning with the second from the bottom, or anchor the wire reel.
2. Slowly pay out the wires down the fenceline staying as close as possible to the posts. Maintain enough tension on the wires to prevent loops and kinks from forming.
3. Smooth, high-tensile wire may be periodically stapled on mid-point posts to guide the wire. Leave staples loose enough for wire to slide through them (see section on "Stapling").
4. Continue to pay out wire to about 152 cm beyond the far end post, maintaining the payout tension on the wires.
5. Position wires on posts with the use of tension sheaves for barbed wire and periodic loose stapling for smooth, high-tensile wire to ensure that wires will be parallel to the ground surface when tightened. Then there is no need to pull up or push down the wires, which would change the tension during final stapling.
6. If an in-line wire strainer is not being used, cut the wire from the reel and attach a tensionmeter to it. If barbed wire is being used, tighten it to 272 kg, then relax it to 136 kg, and tie it off at the end post. Tighten high-tensile wire to 136 kg and tie it off at the end post. If an in-line wire strainer is being used, tie the wire off at an end post without tightening it first. Staple all wires to the brace assembly.
7. If in-line wire strainers (Fig. 12) are used, cut off each wire from the reel, position all wires on the end post and tie them off using an end-post knot or crimped sleeves. Do not tension.
 - a) Return to the mid point of the span; working from the top wire, attach a wire puller about 122 cm from the post and pull the wire tight.
 - b) Cut the wire at the mid point of the slack between the jaws of the wire puller. Install an in-line strainer by threading two compression sleeves onto the wire nearest the post and slide them back about 30 cm. Thread about 15 cm of the wire through the holes in the shank of the in-line strainer and bend the wire back on itself. Slide the sleeves forward to catch the wire and crimp them.
 - c) Thread the line wire through the drum of the in-line strainer and cut off surplus wire close to the drum. Turn the drum to secure the wire and insert the ratchet pin. Continue turning to take up all slack. Remove the wire puller.
 - d) Continue as above for all wires using in-line strainers.
 - e) If an in-line tension-indicator spring is to be used, attach it between the in-line strainer and the line wire in the second wire from the top.

TENSIONING LINE WIRE

Fences constructed with a tensionmeter are tensioned at end posts before tying off. If proper construction techniques are followed, wires are spaced and fences are tensioned to 136 kg at 0°C or equivalent allowing for temperatures. These fences will remain well tensioned after the fence shifts to equilibrium and will need no further tension adjustments at the time of construction.

The method for tightening fences using in-line strainers is as follows:

1. Starting with the wire with the in-line tension spring, attach a handle or wrench and turn the drum of the strainer until the wire is taut and free from other wires.
If in-line tension springs are used, measure the coiled portion of the spring. Continue turning the drum until the coil is shortened 38–45 mm, which will give at least 113 kg tension on the wire.
2. Crank the remaining in-line strainers to about the same tension that was placed on the wire with the in-line tension spring. Check each wire against the spring tensioned wire by pulling toward you until the resistance of each feels the same. With practice, this method is surprisingly accurate.
3. To tension wires without in-line springs, draw the fence taut by cranking up the in-line strainers. Continue cranking the strainer and check the tension by measuring wire deflection using the apparatus and spring scale shown in Fig. 13. After tensioning the first wire, additional wires can be tightened by feel, making final adjustments by measuring deflection pressures with the board and scale.
4. After all wires are tightened, staple all wires at their correct height on all posts following proper stapling techniques. Remove all wire sheaves before stapling.

STAPLING

Staple each wire to the line posts after it has been tensioned. Contrary to popular opinion, never drive staples on line posts tightly against the wire. Driving staples tightly increases friction on the wire and prevents even tension in long spans of wire. It also kinks the wire and results in short rigid spans with little or no elasticity to reduce the stress of livestock pressure against the fence. Tight staples also prevent movement of wires in response to temperature changes and, with imposed loads, stretching of the wires occurs, resulting in sagging or breakage.

Drive staples just tight enough so the wire could be removed and rethreaded through the arch of the protruding staple (Fig. 35). A major failure of wire fences is caused by staples pulling out, which could be the result of several factors, including:

- improper staple used for the job
- wires stapled on the wrong side of the posts for livestock pressure

- wires stapled on inside of posts on curves
- excessive tension in the wires
- staples driven improperly so there is little resistance to pulling.

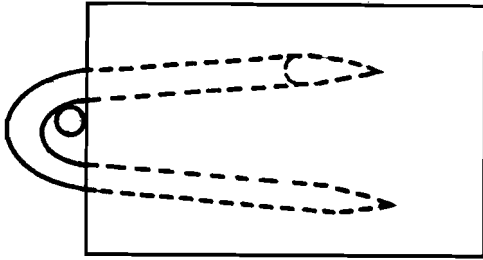

Fig. 35 Proper stapling.

Proper Technique

Follow steps 1 to 6 for the proper stapling technique.

1. Select the correct staples. The longer the staple the greater the hold. Tests show that 45 mm \times 9 gage staples driven in wood posts have 50% more resistance to being pulled out than 38 mm \times 9 gage staples driven into the same posts. For long life, select staples either manufactured from galvanized wire, or hot-dip tumbler galvanized after forming. Staples should have slash-cut points so the legs will bend with driving, giving the staple maximum holding power.
2. Never drive staples vertically into wood posts. Doing so can cause splitting along the grain of the wood, resulting in little holding power of the staple. Rotating the staple slightly off vertical straddles the grain, increasing the holding power of the staple.
3. Drive staples with slash points so their legs curve *outwards* as they penetrate the wood (Fig. 36). The slash cut acts as an asymmetrical wedge forcing the leg to curve away from the flat surface. Tests show that staples driven so that each leg curves away from the vertical centre line have 40% more pull-out resistance than staples driven incorrectly. When placing a staple over the wire against the post, rotate the staple slightly (20° off vertical) *away* from the flat surface of the point on the upper leg (Fig. 37).
4. In dips, drive staples at an upward angle and on rises drive staples at a downward angle (Fig. 38). The wire is then pulling the staple in on the post instead of out.
5. On very steep dips or rises, where there is considerable wire tension pulling on staples, double stapling is advantageous (Fig. 39).
6. When stringing and tensioning line wires around the outside of posts stapling can be used to reduce friction. Simply hang a staple over the securing staple and between the wire and the post so the line wire is sliding on the staple rather than the post (Fig. 40).

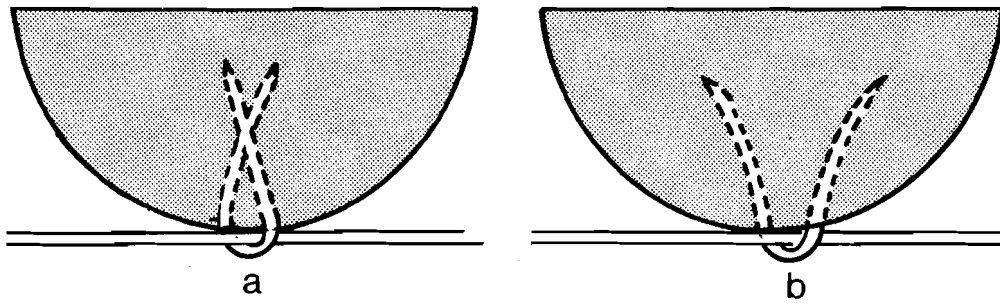

Fig. 36 Staples driven (a) incorrectly and (b) correctly.

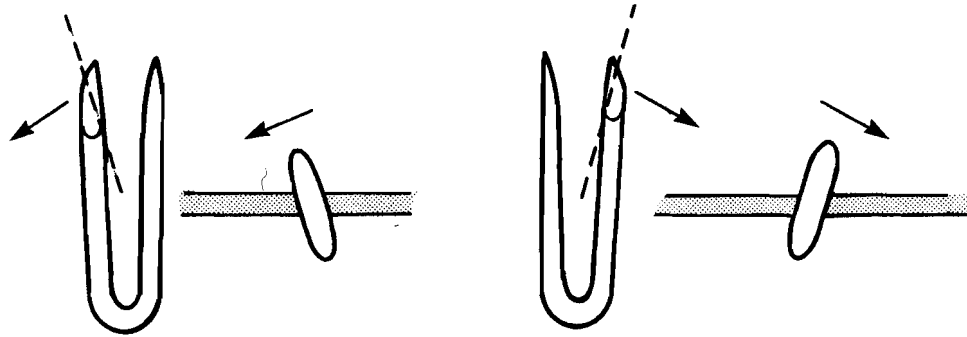

Fig. 37 Staples rotated away from a flat surface.

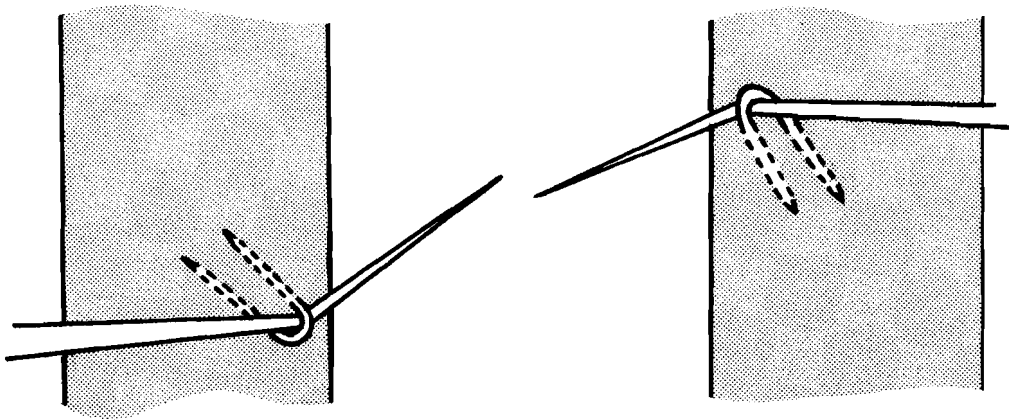

Fig. 38 Stapling rise or dip wires.

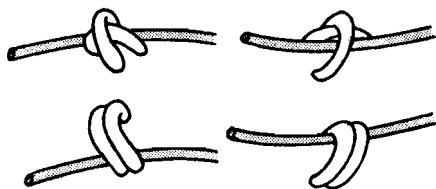

Fig. 39 Double stapling rise or dip wires.

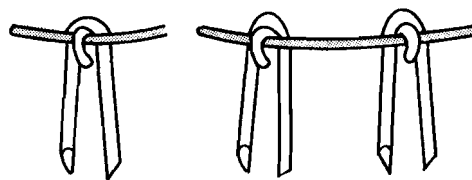

Fig. 40 Stapling around curves or corners.

INSTALLING DROPPERS

Dropper installation is the last operation performed in the erection of a line fence. Attach droppers to the fenceline wires after all wires are properly tightened and after final stapling is complete.

Droppers, acting as wire spacers and load distributors, must be properly installed to function properly. To space wires correctly, they must remain vertical and hold the wire in place. Thus, they must be attached relatively tightly to the wire. At the same time, they must be free to move with the wires while maintaining their position on the wires if they are to distribute a load of impact among the wires.

As previously mentioned, the number or spacing of droppers used is dependent upon livestock pressure on the fences. The greater the livestock pressure on a fence the greater the requirement that wire spacings be rigidly maintained, thus the more closely spaced droppers should be.

Suspension

On fences where the wires are relatively close to the ground (eight or more wires), it is recommended that droppers do not touch the ground, which allows them to move with the wire on impact.

On fences where the bottom wire is 30 cm or more off the ground and where there is small livestock pressure on the bottom wires, it is recommended that a dropper (or a post) be in contact with the ground every 6–9 m. Thus, in an 18-m span, with droppers every 3 m, every second or every third dropper would rest on the ground. These droppers drag with pressure of small livestock (calves) on the bottom of the fence and prevent overturning of the fence.

Methods of attachment

Droppers may be attached onto line wires in one of several ways.

1. Droppers that snap on or use clips are easy to install without prior instruction.
2. Spiral, twisted wire droppers are placed so the legs of the spiral straddle the top wire. Slight downward pressure and guidance by the technician results in the dropper twisting itself onto the fence. Remember, these droppers disfigure with livestock pressure.
3. Wooden droppers of sufficient size can be stapled to the wires.
4. Some droppers are attached with wire knots, depicted in Figs. 41, 42, and 43.

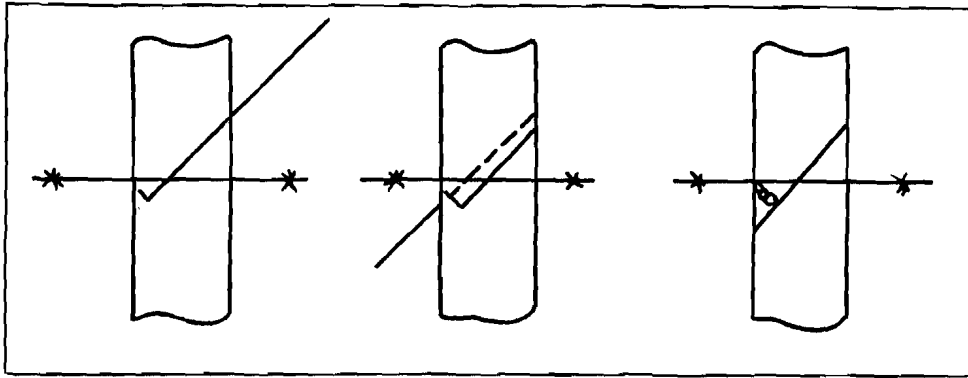

Fig. 41 Single wrap for dropper attachment.

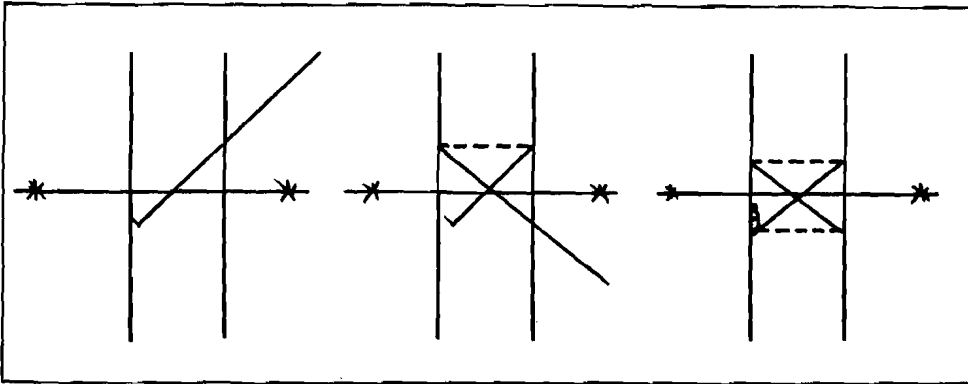

Fig. 42 Figure eight wrap for dropper attachment.

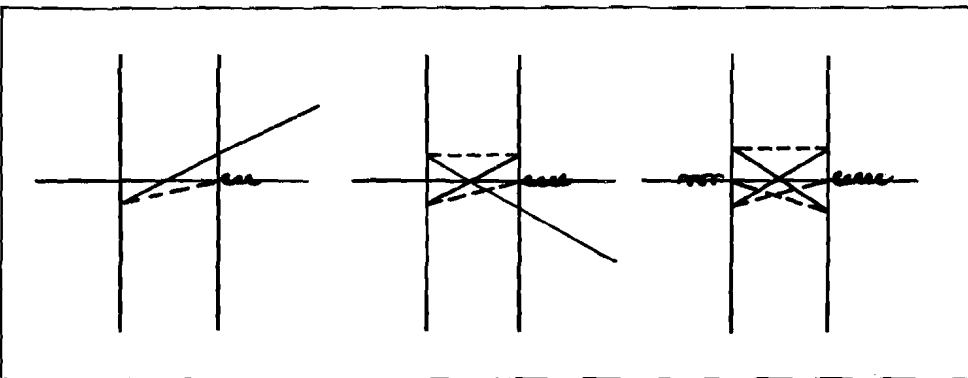

Fig. 43 Figure eight wrap for dropper attachment to high-tensile wire.

GATES

Gates are required in all fences and should be:

- located to enhance, not hinder, farm management
- at least as high as the fence
- wide enough to permit passage of the widest machinery

- level enough, and hinged, to permit free swinging
- as long lived as the fence.

The wider the gate, the greater its tendency to pull over the post on which it is hung. Because of this, install gates on brace or end posts to which line wires have been tied off. Use posts of at least 244 cm × 152 mm and drive them 122 cm into the ground. Site gates some metres from corners or perpendicular fences to facilitate machinery movement. It may be necessary to offset gates in boundary fences along busy roadways. In such cases, panels of boards are better than short sections of wire fence.

The installation of gate hinge pins parallel to fence line wires does not allow the gate to swing back against the fence. Installing the pins 45° off parallel, on the side of the post from which you wish the gate to swing, will allow the gate to swing fully back against the fence (Fig. 44).

A hinged, wire gate (Fig. 45) designed by S. Clark Martin at the University of Arizona is constructed as follows:

1. Tightly fasten the end pieces to the diagonal so the frame is relatively rigid.
2. Hang the frame on the hinges or pivot.
3. Fasten the first wire from the centre of the latch end to the centre of the hinge end.
4. Tighten the first wire to hold the latch end at the desired height.
5. Attach remaining wires, pull them tight enough to hold the latch end vertical.
6. Attach vertical supports as needed.
7. Tighten the frame so it is rigid.
8. Materials required:
 - The diagonal and end pieces can be steel pipe, wooden rails, or a combination of the two.
 - The hinge can be two bolted pivots on the gatepost or one on the post and a buried pipe in the ground.
 - Joints between the diagonal and end pieces can be welded on tabs, flattened pipe, or screwed on angle iron braces for wooden components. They must, however, be tight.

SAFETY

Anyone building a wire fence is subject to cuts and scratches inflicted by the wire. These can be magnified through carelessness when working with high-tension fences. Always take the following safety precautions:

- Wear tough clothing that will not tear easily and that will not readily catch on wire ends or barbs.
- Wear heavy duty, gauntlet-type, leather gloves that fit snugly.
- Wear long pants and work boots with heavy soles to protect feet and legs.

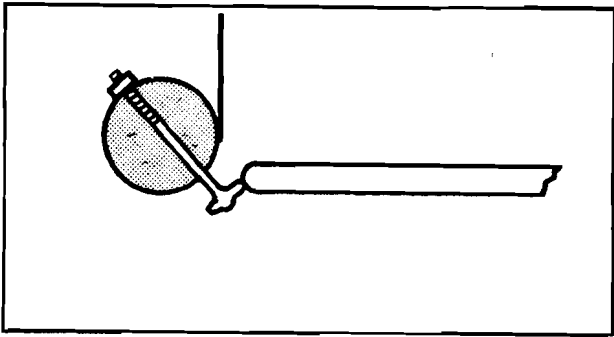

Fig. 44 Hanging gate at 45° allows it to swing fully back against fence.

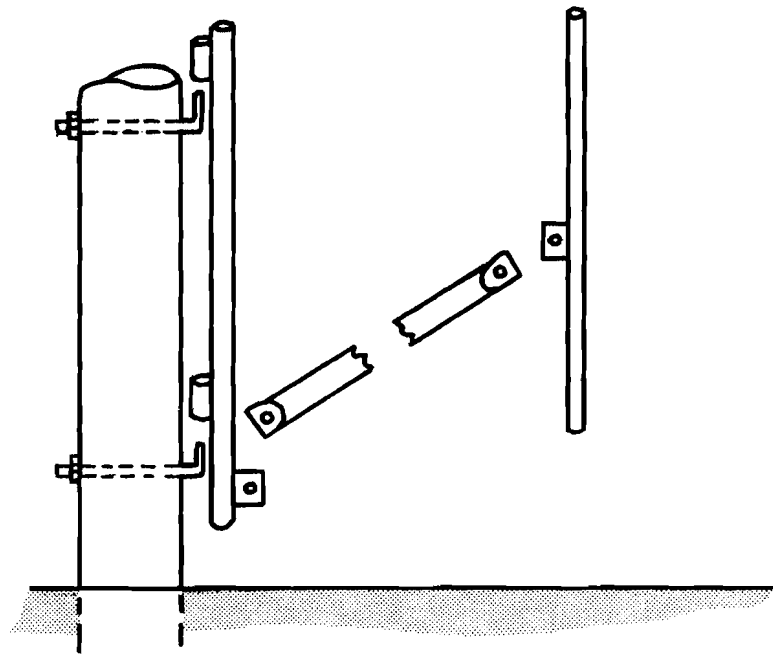
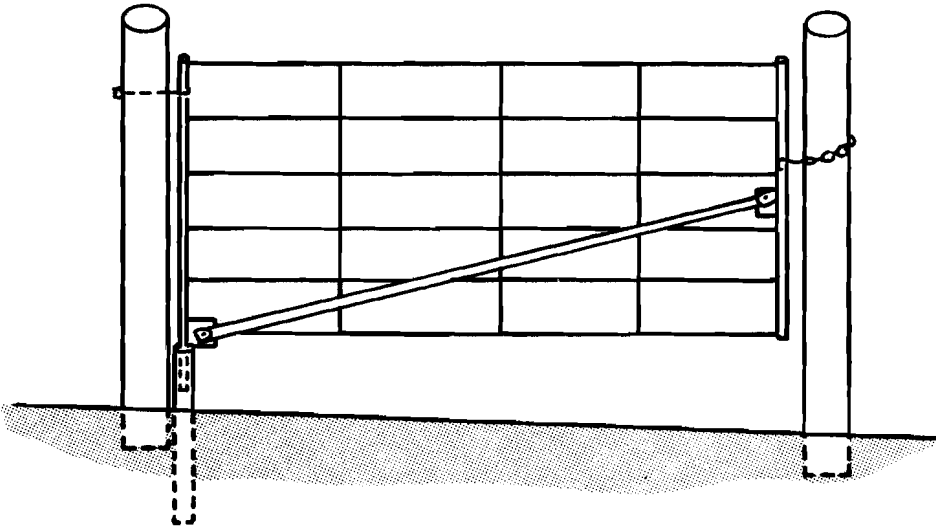

Fig. 45 Hinged wire gate.

- Have the right tools for the job, keep them in good working order, and follow instructions for their use.
- Wear eye protection when cutting or tensioning wire and when driving nails or staples.
- Use proper shields on power equipment.
- Use a nail apron or tool bag to carry nails, staples, and tools.
- Wear a hard hat and ear protection when operating a post pounder.
- Use driving caps on posts to prevent splintering.
- Keep children and livestock away from fencing operations.
- When working with treated posts or lumber, wear protective clothing. Some people are allergic to chemicals.
- Never use unsafe shortcuts.
- Keep the work area free from debris; pick up all pieces of wire, nails, staples, and so on to protect equipment, livestock, and people.

ACKNOWLEDGMENTS

The author gratefully acknowledges Dr. J.W. Zahradnik, Bio Resource Engineering Department, University of British Columbia, for assistance with information on basic principles taken from a research contract "Study on cost reduction of rangeland fence construction in British Columbia" funded by Research Branch, Agriculture Canada. Mr. John Wall, president of Kiwi Fence Systems Inc. of Waynesburg, Pa.; United States Steel Corporation of Pittsburg, Pa.; and numerous others graciously gave permission to reproduce various drawings, tables, and other technical information contained herein.

CONVERSION FACTORS FOR METRIC SYSTEM

Imperial units	Approximate conversion factor	Results in
Length		
inch	× 25	millimetre (mm)
foot	× 30	centimetre (cm)
yard	× 0.9	metre (m)
mile	× 1.6	kilometre (km)
Area		
square inch	× 6.5	square centimetre (cm ²)
square foot	× 0.09	square metre (m ²)
square yard	× 0.836	square metre (m ²)
square mile	× 259	hectare (ha)
acre	× 0.40	hectare (ha)
Volume		
cubic inch	× 16	cubic centimetre (cm ³ , mL, cc)
cubic foot	× 28	cubic decimetre (dm ³)
cubic yard	× 0.8	cubic metre (m ³)
fluid ounce	× 28	millilitre (mL)
pint	× 0.57	litre (L)
quart	× 1.1	litre (L)
gallon (Imp.)	× 4.5	litre (L)
gallon (U.S.)	× 3.8	litre (L)
Weight		
ounce	× 28	gram (g)
pound	× 0.45	kilogram (kg)
short ton (2000 lb)	× 0.9	tonne (t)
Temperature		
degrees Fahrenheit	(°F - 32) × 0.56 or (°F - 32) × 5/9	degrees Celsius (°C)
Pressure		
pounds per square inch	× 6.9	kilopascal (kPa)
Power		
horsepower	× 746 × 0.75	watt (W) kilowatt (kW)
Speed		
feet per second	× 0.30	metres per second (m/s)
miles per hour	× 1.6	kilometres per hour (km/h)
Agriculture		
gallons per acre	× 11.23	litres per hectare (L/ha)
quarts per acre	× 2.8	litres per hectare (L/ha)
pints per acre	× 1.4	litres per hectare (L/ha)
fluid ounces per acre	× 70	millilitres per hectare (mL/ha)
tons per acre	× 2.24	tonnes per hectare (t/ha)
pounds per acre	× 1.12	kilograms per hectare (kg/ha)
ounces per acre	× 70	grams per hectare (g/ha)
plants per acre	× 2.47	plants per hectare (plants/ha)